



FORESTRY EQUIPMENT WAREHOUSE CATALOG

5-2024



PRICES SUBJECT TO CHANGE

Visit us on the web at: <http://dnr.wi.gov/topic/forestfire/catalog>



Forestry Equipment R&D Center

The Forestry Equipment R&D Center is a critical component of the Wisconsin DNR's fire control program. Wisconsin's fire control program is regarded nationally as a leader in initial attack fire fighting, in part due to the quality and effectiveness of the equipment designed, fabricated and serviced by the Equipment Center.

Our warehouse services DNR personnel, government agencies, and cooperating non-profit organizations all across the state of Wisconsin. We offer a wide range of Wildland fire fighting equipment and supplies. Through bulk purchasing and a competitive bid process, we are able to provide these items to our customers at a much lower cost.

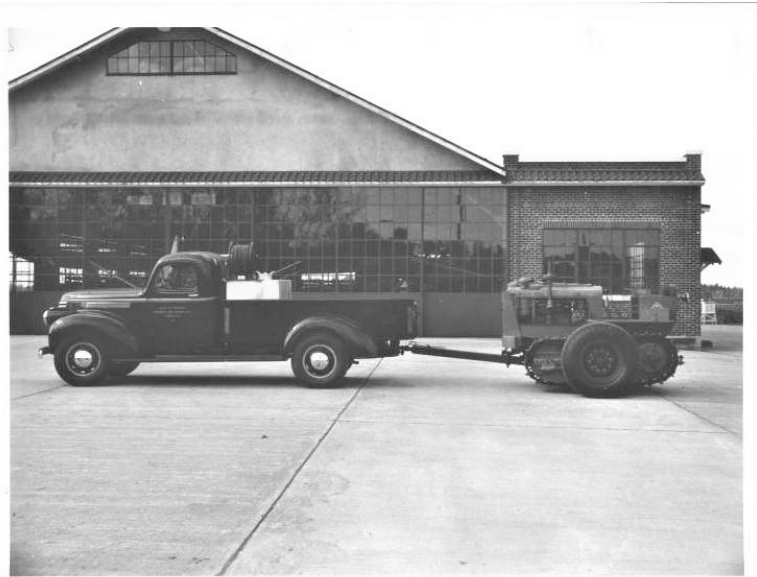

Since 1934, the Center has matched changing needs with growing capability. The basic purpose for serving people and their resources remains constant.

Phone: 715-453-1257

Fax: 715-453-5998

E-mail: DNRFRStockroom@wisconsin.gov

Order Form

A copy of the order form can be found online at:

<https://dnr.wisconsin.gov/sites/default/files/topic/ForestFire/OrderForm.pdf>

For the order form to work, you must save/download it to your computer, then open it with Acrobat Reader before filling it in. **If you use a browser PDF reader to complete it, the form will not work properly.** We recommend you save a copy after you complete the form, then email a copy of the completed form to DNRFRStockroom@wisconsin.gov.

Pickup

You can always pick up your order. Just submit your order and call to make arrangements for pick up. Generally we are available for pickup Monday-Friday 8:30-11:30 & 12:30-4:00

Damaged Goods

In the event you receive a damaged or short shipment, you must immediately file a claim with the carrier. Under ICC regulations this claim is the consignee's (your) responsibility. Please contact our Stockroom 715-453-1257 or DNRFRStockroom@wisconsin.gov for assistance.

Returns

When returning any part of your order, please contact our Stockroom 1-715-453-1257 or DNRFRStockroom@wisconsin.gov FIRST and include your LeMay order# and the specifics of your situation. If you will be returning a package you can print out and fill in the [LeMay Warranty/Return Form](#). Enclose the form in the package. Carefully repackage the merchandise using the original packing material if possible, to prevent damage in transit. All items that are returned should be in the same condition as when delivered.

Catalog Errors

Due to the wide selection of products being offered, there may be occasional errors found in the catalog. We reserve the right to make corrections in the event of a misprint or change.

We appreciate any, and all feedback on your experience. Please complete the survey and return it to us.

[Customer Satisfaction Survey \(wisconsin.gov\)](#)

Email at DNRFRStockroom@wisconsin.gov

Phone: (715) 453-1257

Contacts:

[Holly Lund](#)
(715) 453-2180

[Keshia Bentley](#)
(715) 453-2189

TABLE OF CONTENTS

<u>BACKPACK PUMPS & PARTS</u>	<u>5-8</u>
<u>BACKFIRING EQUIPMENT</u>	<u>9-10</u>
<u>FIRE FIGHTING HANDTOOLS</u>	<u>11</u>
<u>FIRE RESISTANT CLOTHING</u>	<u>12-18</u>
<u>SAFETY</u>	<u>19-26</u>
<u>PACKS & COMPONENTS</u>	<u>27-29</u>
<u>CANTEENS, COOLERS & PAILS</u>	<u>30</u>
<u>HOSE, FITTINGS & ACCESSORIES</u>	<u>31-36</u>
<u>PUMPS, PARTS & ACCESSORIES</u>	<u>37-47</u>
<u>FOAM UNITS & ACCESSORIES</u>	<u>48-49</u>
<u>HOSE REELS & PARTS</u>	<u>50</u>
<u>WINCHES & ACCESSORIES</u>	<u>51-52</u>
<u>DECALS</u>	<u>53</u>
<u>SIGNS & PARTS</u>	<u>54-59</u>
<u>FORESTRY EQUIPMENT</u>	<u>60-67</u>
<u>VALVES & STRAINERS</u>	<u>68-70</u>
<u>TRUCK PARTS—ELECTRICAL</u>	<u>71-74</u>
<u>TRACTOR PLOW PARTS</u>	<u>75-76</u>
<u>SPECIALTY ASSEMBLIES & PARTS</u>	<u>77-80</u>
<u>CHAIN, HOOKS & BINDERS</u>	<u>81</u>

BACKPACK PUMPS & PARTS



Backcan, Complete

Five-gallon tank features baffle, outlet with filter screen at bottom, 1" recessed bottom, and ventilated back rest. Slide action pump is operated by hand. Gasketed cam lock tank cap features a ventilation hole to prevent tank collapse, and is secured to the tank by a 4" beaded chain. Combination nozzle allows quick change from spray to straight stream. Single-braided, flexible, oil-resistant hose, 1/2" I.D., 30" long. Carrying handle has clips for securing pump and holes for attaching removable, 1-3/4" heavy-duty polypropylene shoulder straps. One strap has clip for attaching pump to your chest. Net Weight: 12 lbs., 5 oz.

Part # 340-36-10-9000 \$172.70

FOR PARTS INFORMATION SEE PAGE 7

Collapsible Backpack Pump, Complete

5 Gallon Heavy Duty Vinyl bag - rolls up to fit in small areas when not in use. Shoulder Harness Straps offer the best in comfort with center cinch strap that distributes weight efficiently and comfortably. Seams are electronically sealed and reinforced at all stress points. Dual Nozzle changes quickly from stream to spray without tools.

Part # 340-36-20-1001 \$135.20

PARTS INFORMATION BELOW EXCEPT BRASS HAND PUMP — SEE PAGE 8 FOR HAND PUMP PARTS



Backpack Pump, Female Quick Connect

Replacement hose connection for firefighter's backpack pump outfit. Made of brass, cadmium-plated steel or stainless steel. Attaches to tank opening for Collapsible Backpack Pump. Female connection with male screw threads. Forest Service Spec 5100-257.

Part # 340-36-20-0429 \$9.65

Backpack Pump, Male Quick Connect

Replacement hose connection for firefighter's backpack pump outfit. Made of brass, cadmium-plated steel or stainless steel. Attaches to inlet on Collapsible Backpack Pump. Male quick-connect with male barbed hose connection. Forest Service Spec 5100-256.

Part # 340-36-20-0428 \$8.05



Backpack Pump, Liner

Replacement bladder for Collapsible Backpack Pump. Does not include a quick-connect fitting. **Note: Not safe for use with drinking water bag.**

Part # 340-36-20-0597 \$9.65



BACKPACK PUMPS & PARTS

Backcan, Pump Only, Brass

For use with Backcan and Collapsible Backpack Pump.

Part # 340-36-11-5111

\$78.70



[FOR PARTS INFORMATION SEE PAGE 7](#)



Collapsible Backpack, Hand Pump with Hose Assy

Trombone-style, plunger-type pump includes a quick-connect fitting. Positive-displacement, single action type features screw-on combination solid straight-stream and fog nozzle. For use with Backpack Pump Outfit NSN 4320-00-289-8912. Forest Service Spec 5100-256.

Part # 340-36-20-0762

\$70.67

[FOR PARTS INFORMATION SEE PAGE 8](#)



BACKPACK PUMPS & PARTS

Replacement Parts for Backcan, Pump Only, Brass (#340-36-11-5111)

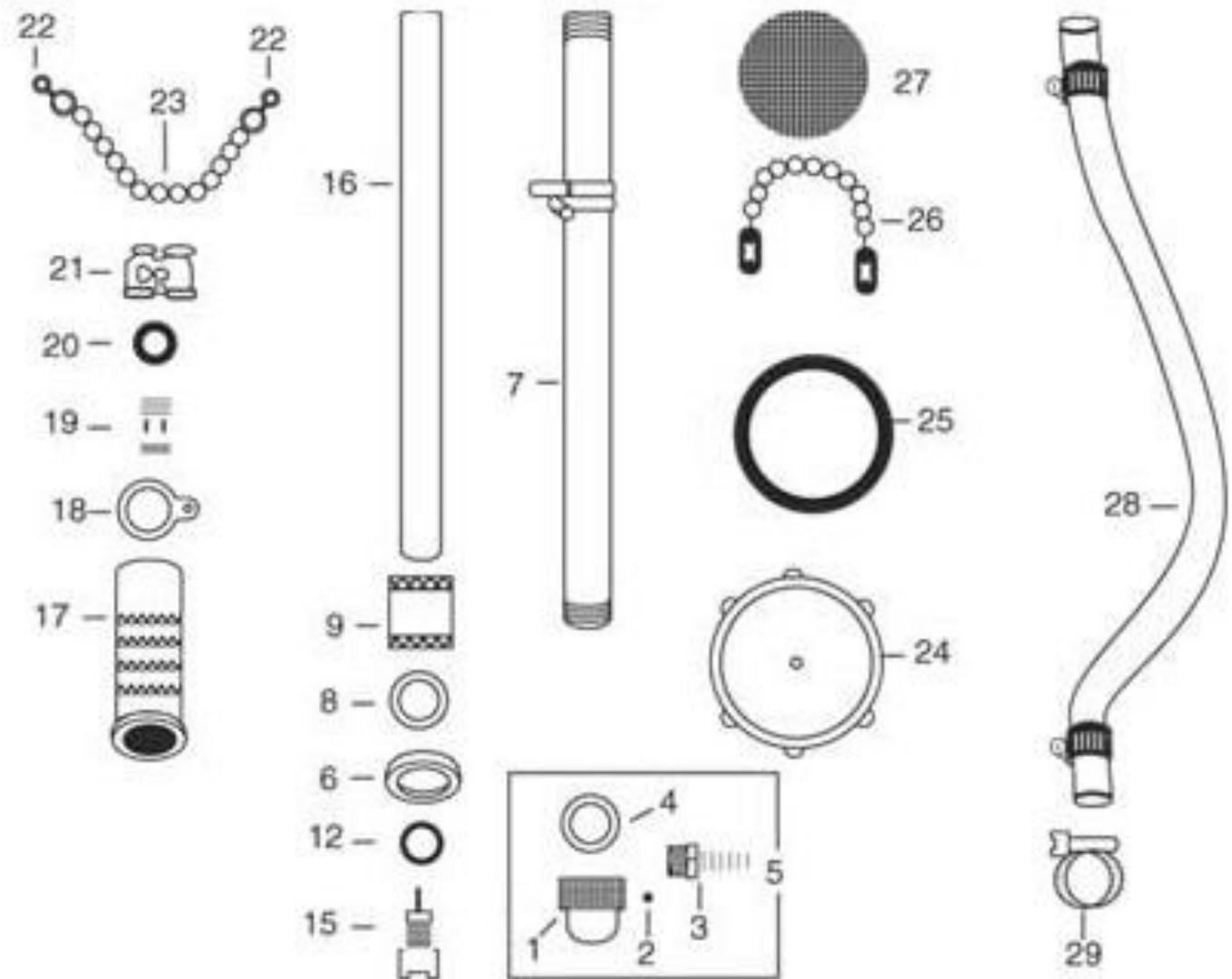

REF PART #	DESCRIPTION	PRICE
340-36-11-0001	Repair Kit	\$27.50
1 340-36-11-2494	Pump Base	\$3.00
2 340-36-11-0010	Check Ball	\$0.80
3 340-36-11-1000	Hose Nipple	N/C
4 340-36-11-5986	Gasket, Pump Base	\$1.00
5 340-36-11-5931	Pump Base Assembly	\$5.50
6 340-36-11-5961	Guide Sleeve	\$3.00
7 340-36-11-5942	Outside Cylinder	\$21.20
8 340-36-11-5950	U-Ring	\$1.19
9 340-36-11-5949	Gland Nut	\$7.00
12 340-36-11-1089	O-Ring, Check Valve	\$0.66
15 340-36-11-5951	Check Valve	\$19.50

REF PART #	DESCRIPTION	PRICE
16 340-36-11-5947	Inside Cylinder	\$12.46
17 340-36-11-5958	Handle	\$12.75
18 340-36-11-5962	Teardrop Ring	\$0.50
19 340-36-11-5963	Nozzle Nipple	\$2.75
20 340-36-11-5707	Nozzle Gasket	\$0.63
21 340-36-21-1559	Dual Nozzle	\$13.75
23 340-36-11-5937	Nozzle Chain	\$1.25
24 340-36-11-5096	Tank Cover	\$8.00
25 340-36-11-5097	Gasket, Tank Cover	\$2.38
26 340-36-11-5072	Chain, Tank Cover	\$4.15
27 340-36-11-5238	Fill Strainer	\$11.00
28 340-36-11-6084	Hose, 1/2" x 30"	\$2.73



BACKPACK PUMPS & PARTS

Replacement Parts for Collapsible Backpack, Hand Pump with Hose Assy (#340-36-20-0762)

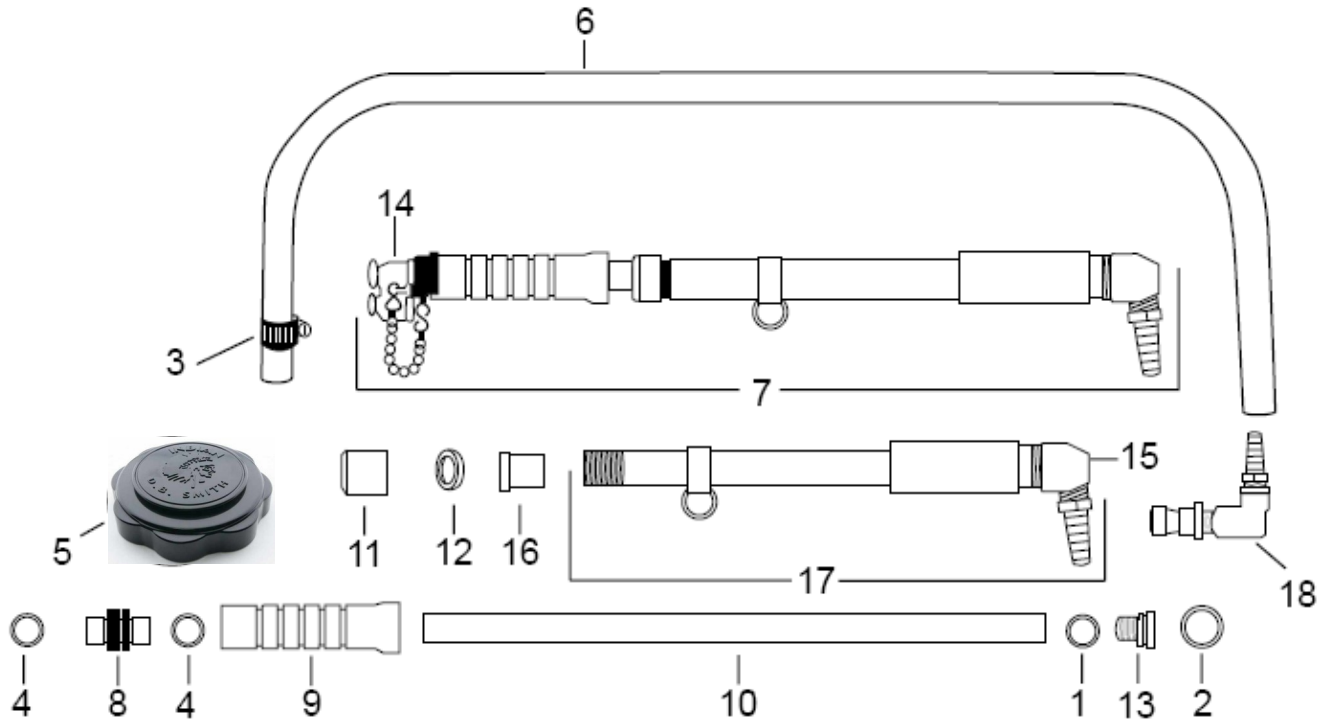

REF	PART #	DESCRIPTION	PRICE
1	340-36-21-1033	O-Ring, Piston, Small, #1033	\$1.00
2	340-36-21-1035	O-Ring, Piston, Large, #1035	\$1.00
3	N/A	Hose Clamp, Stainless Steel #8	N/A
4	340-36-11-5707	Nozzle Gasket #5707	\$0.63
5	340-36-21-5171	Cap with O-ring	\$2.00
6	N/A	Hose—30"	N/A
7	340-36-20-0762	Pump Assembly w/hose & fitting	\$70.67
8	340-36-21-5773	Nozzle Bushing #5773	\$5.95
9	340-36-21-5781	Handle #5781	\$15.95
10	340-36-21-5783	Inside Cylinder #5783	\$20.50
11	340-36-21-5785	Cap Nut #5785	\$17.25
12	340-36-21-5786	Felt Wiping Ring #5786	\$0.60
13	340-36-21-5788	Piston Assembly #5788	\$19.50
14	340-36-21-1559	Nozzle, Dual	\$13.75
15	340-36-21-5931	Pump Base with Check Valve. #5931	\$14.80
16	340-36-21-5787	Nylon Bushing #5787	\$2.50
17	340-36-21-5863	Outside Cylinder #5863	\$36.50
18	340-36-21-5159	Filler Neck Kit	\$12.95



BACKFIRING EQUIPMENT



Fusee

For starting backfires, this device features positive-ignition action similar to highway flares. Burns for 10 minutes. Forest Service Spec 5100-360.

Part # 340-04-20-0105 \$3.75

Drip Torch

Constructed from 15 gauge seamless aluminum with a rugged forged aluminum bottom to prevent wear and punctures. The spout is reversible for storage. A breathing tube with a shut-off prevents fuel leaks when in the storage mode. Parts are interchangeable with most other drip torches. 1.25 gal capacity. DOT approved USFS 5100-614A

Part # 340-04-10-1000 \$146.51

Bracket, Drip Torch

Truck mount bracket is designed to keep drip torch in an upright position. It is made from rust resistant material.

Part # 340-06-05-1001 \$70.35



FOR PARTS INFORMATION SEE PAGE 10



BACKFIRING EQUIPMENT

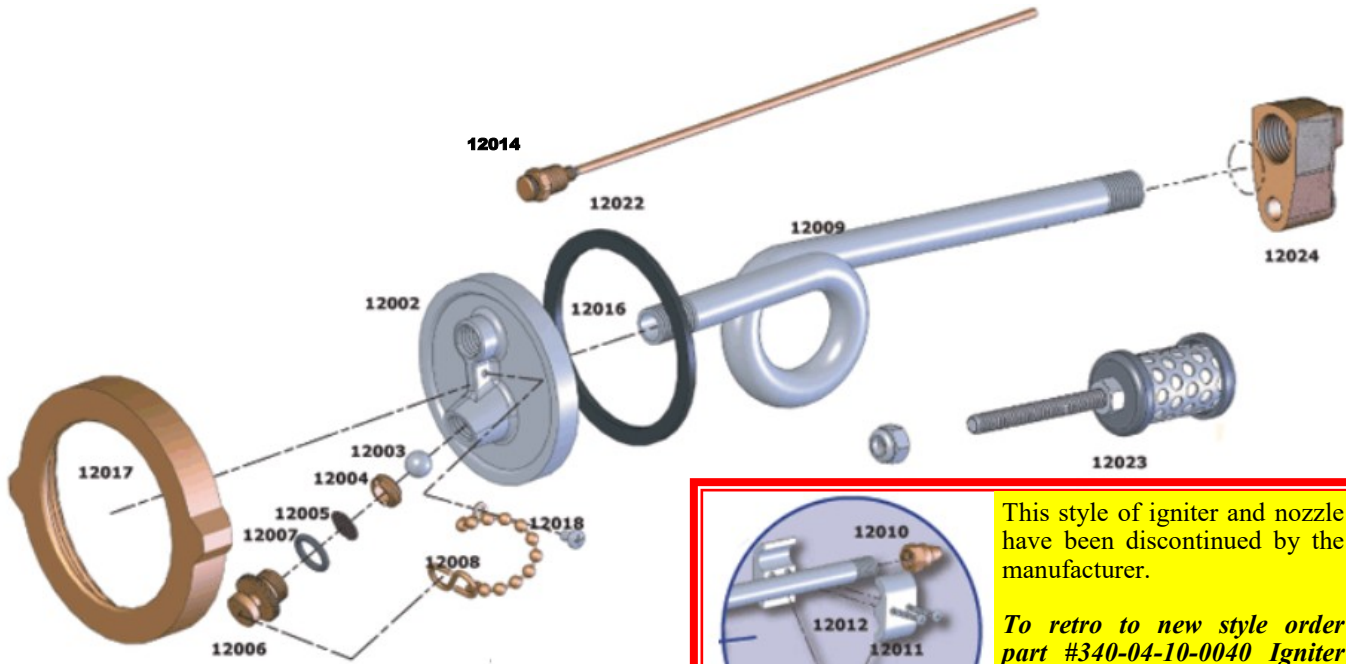

This style of igniter and nozzle have been discontinued by the manufacturer.

To retro to new style order part #340-04-10-0040 Igniter & Nozzle Assy. This includes parts 12023 & 12024. Price is \$34.71 each.

Ref	Part #	Description	Price
12002	340-04-10-0004	Cover	\$26.36
12003	340-04-10-0005	Ball	\$1.97
12004	340-04-10-0006	Seat	\$3.84
12005	340-04-10-0007	Screen	\$4.78
12006	340-04-10-0008	Plug, Discharge	\$5.68
12007	340-04-10-0009	O-Ring, Discharge Plug	\$1.53
12008	340-04-10-0017	Chain, Discharge Plug	\$5.75

Ref	Part #	Description	Price
12009	340-04-10-0011	Spout & Fuel Trap	\$26.46
12014	340-04-10-0014	O-Ring, Breather Tube	\$0.80
12016	340-04-10-0022	Gasket, Cover	\$3.10
12017	340-04-10-0023	Lock Ring, Cover	\$31.55
12022	340-04-10-0035	Breather Tube	\$23.30
12023	340-04-10-0025	Igniter (use with #12024)	\$21.05
12024	340-04-10-0026	Nozzle (with igniter mount)	\$15.80



FIRE FIGHTING HANDTOOLS

Fire Shovel

Designed especially for fighting wildland fires. Features a solid shank and a straight 41" handle. Forest Service Spec 5100-326.



Part # 340-40-30-0171 \$74.61



Fire Rake

Council or Rich tool is designed for fire-line digging. Features triangular cutting heads on a 12"-wide hoe-type frame. Consists of four mowing machine cutter blades riveted to a steel frame. Straight handle is 52" long. Forest Service Spec 5100-284

Part # 340-40-20-1807 \$45.25

Pulaski Tool

This ax-and-hoe combination tool is designed for fire-line digging and chopping. Cutting edges: 3-3/8" (hoe); 4-1/2" (ax); handle 36" long. Forest Service Spec 5100-355.



Part # 340-40-10-0146 \$72.68



Combo Tool

Combination pick and shovel can be folded for easy transport. Similar to an army entrenching tool and features a 41" handle and serrations on shovel edges for cutting light brush. Intended for use on wildland fire-lines and for general forest work and trail maintenance. Forest Service Spec 5100-325.

Part # 340-40-40-1180 \$81.32

McLeod Tool

Fire-line digging tool is a rake-and-hoe combination. Handle is 48" long. Forest Service Spec 5100-353.



Part # 340-40-20-0296 \$68.50



Fire Swat

A valuable tool when trying to suppress grass and grain fires, range fires, or for mop up work following water equipment. Constructed of heavy rubber made from treated belting, the fire flap features a large 15" flap, with a 60" handle. Overall length is 75". Weight is 5.5 lbs.

Part # 340-40-40-1005 \$56.24

Axe, Single Bit

Boy's-style ax includes a 24"-long hickory handle, which is secured with adhesive bonding and a plastic wedge. Features a 2-1/4-lb. head and a 4"-wide cutting edge. Forest Service Spec 5100-9.

Part # 340-40-10-0352 \$21.10



FIRE RESISTANT CLOTHING

Fire Resistant Coveralls

UL® classified to meet or exceed NFPA* protective clothing requirements for Wildland Fire. Pleated back expands for easy maneuverability. Reinforced elastic waistband provides a comfortable fit. Contoured deep front pockets' special pass-through design allows access to trousers. Full length front zipper opens from top or bottom. Extra reinforced crotch seam. Front fly cover protects and secures the front zipper. Reflective trim at ankles and pockets.



Chest Sizes:
 Small (34-36)
 Medium (38-40)
 Large (42-44)
 X-Large (46-48)
 2X-Large (50-52)
 3X-Large (54-56)

Length:
 Regular— 5'8" to 6'
 Tall—6'1" to 6'4"

Size	Part #	Price
Small	514-03-02-1005	\$220.86
Medium	514-03-02-2005	\$220.86
Medium Tall	514-03-02-2010	\$220.86
Large	514-03-02-3005	\$220.86
Large Tall	514-03-02-3010	\$220.86
X-Large	514-03-02-4005	\$220.86
X-Large Tall	514-03-02-4010	\$220.86
2X-Large	514-03-02-5005	\$242.95
2X-Large Tall	514-03-02-5010	\$242.95
3X-Large	514-03-02-6005	\$267.25
3X-Large Tall	514-03-02-6010	\$267.25



Fire Resistant Coat, DNR

Meets NFPA 1977, current edition, standard for wildland fire fighting protective clothing and UL classified. These brush coats feature large breast pockets, two large hip pockets with full flap closures, roomy raglan style sleeves, a turnout style collar with self-storing throat strap, and adjustable hook and loop cuff closures. 2" reflective stripe at waist, forearm and upper back. The words "WISCONSIN FIRE" on the back are reflective. **COATS COME WITH A LINER**



Fire Resistant Coat Liner

6.5oz. Cotton liner buttons into our fire resistant coats for added warmth.

Chest Sizes:
 Small (34-36)
 Medium (38-40)
 Large (42-44)
 X-Large (46-48)
 2X-Large (50-52)
 3X-Large (54-56)

Size	DNR Coat	Price	Liner	Price
Small	513-13-10-1005	\$153.68	513-04-01-1005	\$26.91
Medium	513-13-10-2005	\$153.68	513-04-01-2005	\$26.91
Medium Tall	513-13-10-2010	\$153.68	513-04-01-2010	\$26.91
Large	513-13-10-3005	\$153.68	513-04-01-3005	\$26.91
Large Tall	513-13-10-3010	\$153.68	513-04-01-3010	\$26.91
X-Large	513-13-10-4005	\$153.68	513-04-01-4005	\$26.91
X-Large Tall	513-13-10-4010	\$153.68	513-04-01-4010	\$26.91
2X-Large	513-13-10-5005	\$169.05	513-04-01-5005	\$29.60
2X-Large Tall	513-13-10-5010	\$169.05	513-04-01-5010	\$29.60
3X-Large	513-13-10-6005	\$184.42	513-04-01-6005	\$32.29
3X-Large Tall	513-13-10-6010	\$184.42	513-04-01-6010	\$32.29



FIRE RESISTANT CLOTHING

Fire Resistant Pants

All of our fire resistant pants are manufactured to include BDU style, elastic waist, adjustable hook & loop cinch straps at ankles, two front, two cargo & two rear pockets. Includes 2" reflective stripe at ankles and 1" on pockets.

OTHER SIZES AVAILABLE UPON REQUEST

Waist Sizes

Small 27"-30"

Large 35"-38"

2X-Large 43"-46"

Medium 31"-34"

X-Large 39"-42"

3X-Large 47"- 50"

INSEAM: S—28" L/T-32" XL/XT-34"

FR Pants, Advance

7.0 oz "Advance" 60% Kevlar/40% Nomex IIIA.

FR Pants, Tecasafe

9.0 oz Tecasafe material.



Size	Advance	Price	Tecasafe	Price
Small x 28	511-33-14-1000	\$296.00	511-33-16-1000	\$193.10
Small x 31	511-33-14-1005	\$296.00	511-33-16-1005	\$193.10
Medium x 28	511-33-14-2000	\$296.00	511-33-16-2000	\$193.10
Medium x 31	511-33-14-2005	\$296.00	511-33-16-2005	\$193.10
Medium x 34	511-33-14-2010	\$296.00	511-33-16-2010	\$193.10
Large x 28	511-33-14-3000	\$296.00	511-33-16-3000	\$193.10
Large x 31	511-33-14-3005	\$296.00	511-33-16-3005	\$193.10
Large x 34	511-33-14-3010	\$296.00	511-33-16-3010	\$193.10
X-Large x 28	511-33-14-4000	\$296.00	511-33-16-4000	\$193.10
X-Large x 31	511-33-14-4005	\$296.00	511-33-16-4005	\$193.10
X-Large x 34	511-33-14-4010	\$296.00	511-33-16-4010	\$193.10
2X-Large x 28	511-33-14-5000	\$325.60	511-33-16-5000	\$212.41
2X-Large x 31	511-33-14-5005	\$325.60	511-33-16-5005	\$212.41
2X-Large x 34	511-33-14-5010	\$325.60	511-33-16-5010	\$212.41
3X-Large x 31	511-33-14-6005	\$328.44	511-33-16-6005	\$214.22
3X-Large x 34	511-33-14-6010	\$328.44	511-33-16-6010	\$214.22



FIRE RESISTANT CLOTHING

Size	Part #	Price
Small	512-33-23-1005	\$99.73
Medium	512-33-23-2005	\$99.73
Medium Tall	512-33-23-2010	\$99.73
Large	512-33-23-3005	\$99.73
Large Tall	512-33-23-3010	\$99.73
X-Large	512-33-23-4005	\$99.73
X-Large Tall	512-33-23-4010	\$99.73
2X-Large	512-33-23-5005	\$109.70
2X-Large Tall	512-33-23-5010	\$109.70
3X-Large	512-33-23-6005	\$120.67
3X-Large Tall	512-33-23-6010	\$120.67

Fire Resistant Shirt—Men's

Fire resistant shirt is designed for use by wildland firefighters. It is single-breasted with a button front, rolled collar, and straight cut bottom. The shirt has two flap closing breast pockets and hook & pile fasteners for pockets and cuffs.



Chest Sizes:
 Small (34-36)
 Medium (38-40)
 Large (42-44)
 X-Large (46-48)
 2X-Large (50-52)
 3X-Large (54-56)

Fire Resistant Jacket, Fleece—MENS **FOR DNR PURCHASE ONLY.**

The same softness, warmth, breathability, and insulating performance of your favorite fleece jacket, but with full FR construction and materials. A high, two-layer collar and cuffs provide extra warmth. The lightweight double-sided fleece dries quickly. Navy Blue color with 1" triple trim reflective striping as shown.

Size	Part #	Price
Small	513-13-33-1005	\$358.40
Medium	513-13-33-2005	\$358.40
Large	513-13-33-3005	\$358.40
X-Large	513-13-33-4005	\$358.40
2X-Large	513-13-33-5005	\$394.24
3X-Large	513-13-33-6005	\$430.08



FIRE RESISTANT CLOTHING

Size	Part #	Price
X-Small	512-33-25-0005	\$94.15
Small	512-33-25-1005	\$94.15
Medium	512-33-25-2005	\$94.15
Large	512-33-25-3005	\$94.15
X-Large	512-33-25-4005	\$94.15
2X-Large	512-33-25-5005	\$103.57

NEW ITEM

Fire Resistant Shirt—WOMEN'S

Fire resistant shirt is designed for use by wildland firefighters. It is single-breasted with a button front, rolled collar, and straight cut bottom. The shirt has two flap closing breast pockets and hook & pile fasteners for pockets and cuffs.



Size	Advance	Price	Nomex/ Tecasafe	Price
6P	511-33-13-0600	\$360.00	511-33-12-0600	\$275.00
6R	511-33-13-0605	\$360.00	511-33-12-0605	\$275.00
6L	511-33-13-0610	\$360.00	511-33-12-0610	\$275.00
8P	511-33-13-0800	\$360.00	511-33-12-0800	\$275.00
8R	511-33-13-0805	\$360.00	511-33-12-0805	\$275.00
8L	511-33-13-0810	\$360.00	511-33-12-0810	\$275.00
10P	511-33-13-1000	\$360.00	511-33-12-1000	\$275.00
10R	511-33-13-1005	\$360.00	511-33-12-1005	\$275.00
10L	511-33-13-1010	\$360.00	511-33-12-1010	\$275.00
12P	511-33-13-1200	\$360.00	511-33-12-1200	\$275.00
12R	511-33-13-1205	\$360.00	511-33-12-1205	\$275.00
12L	511-33-13-1210	\$360.00	511-33-12-1210	\$275.00
14P	511-33-13-1400	\$360.00	511-33-12-1400	\$275.00
14R	511-33-13-1405	\$360.00	511-33-12-1405	\$275.00
14L	511-33-13-1410	\$360.00	511-33-12-1410	\$275.00
16P	511-33-13-1600	\$360.00	511-33-12-1600	\$275.00
16R	511-33-13-1605	\$360.00	511-33-12-1605	\$275.00
16L	511-33-13-1610	\$360.00	511-33-12-1610	\$275.00
18P	511-33-13-1800	\$360.00	511-33-12-1800	\$275.00
18R	511-33-13-1805	\$360.00	511-33-12-1805	\$275.00
18L	511-33-13-1810	\$360.00	511-33-12-1810	\$275.00

Fire Resistant Pants - WOMEN'S

Our women's pants are stocked in response to the needs of women firefighters. Designed to comfortably fit the female figure, yet rugged enough to meet the demands of wildland firefighting. Made to all the same high quality standards and specifications as our regular fire resistant pants, our women's pants feature a smaller rise and less "bulk," allowing you to move freely on the fireline. Made of 7 oz Advance or Tecasafe® in Green and have the same reflective striping as our other fire resistant pants.

**INSEAM
LENGTH**
P—30"
R—32"
L—34"



FIRE RESISTANT CLOTHING

Fire Resistant Jacket, Fleece—*WOMEN'S FOR DNR PURCHASE ONLY.*

The same softness, warmth, breathability, and insulating performance of your favorite fleece jacket, but with full FR construction and materials. A high, two-layer collar and cuffs provide extra warmth. The lightweight double-sided fleece dries quickly. Navy Blue color with 1" triple trim reflective striping as shown.

Classic women's cut. Narrower at the shoulders and slightly flared at the waist.



Size	Part #	Price
Small	513-13-43-1005	\$349.21
Medium	513-13-43-2005	\$349.21
Large	513-13-43-3005	\$349.21
X-Large	513-13-43-4005	\$349.21
2X-Large	513-13-43-5005	\$384.13



Shirt; Base Layer, Short Sleeve—*FOR DNR PURCHASE ONLY.*

DriGuard FR Short Sleeve Crewneck – Khaki. Includes Black FR Silk Screen “WISCONSIN FIRE” – on left chest and back.

Size	Regular	Tall	Price
Small	512-33-05-1005		\$35.12
Medium	512-33-05-2005	512-33-05-2010	\$35.12
Large	512-33-05-3005	512-33-05-3010	\$35.12
X-Large	512-33-05-4005	512-33-05-4010	\$35.12
2X-Large	512-33-05-5005	512-33-05-5010	\$38.63
3X-Large	512-33-05-6005	512-33-05-6010	\$42.14

Shirt; Base Layer, Long Sleeve—*FOR DNR PURCHASE ONLY.*

DriGuard FR Long Sleeve Crewneck – Black with elasticized rib knit collar and cuffs. Yellow FR Silk Screen “WISCONSIN FIRE” – on left chest and back.



Size	Regular	Tall	Price
Small	512-33-10-1005		\$43.94
Medium	512-33-10-2005	512-33-10-2010	\$43.94
Large	512-33-10-3005	512-33-10-3010	\$43.94
X-Large	512-33-10-4005	512-33-10-4010	\$43.94
2X-Large	512-33-10-5005	512-33-10-5010	\$48.33
3X-Large	512-33-10-6005	512-33-10-6010	\$52.73



FIRE RESISTANT CLOTHING

Fire Resistant Neck Protector

Full Nomex®, unlined, ear, neck and face protector. Constructed from yellow 7.5 oz Nomex® IIIA for optimal protection. Pressure-sensitive hook and loop tabs allow easy installation in any wildland helmet. Nomex® thread used throughout.

Part # 345-72-10-1004 \$20.86



Fire Resistant Hood, Carbon Shield

State-of-the-art flame-resistant fabrics, assuring permanent flame and heat protection even after years of use and repeated laundering. Longer front and back drape design makes sure the hood stays tucked in even during the most strenuous activity. Other features include flat stitching and seamless chin area for better fit and comfort, 1/2"W elastic face opening which stretches to a full 17" for easy donning and a snug fit, and bottom edge is bound with self-fabric bias binding. For additional peace of mind these hoods (construction and fabrics) are UL classified to meet or exceed the NFPA 1971 Standard on Protective Ensemble for Structural Fire Fighting 2000 Edition.

Part # 345-72-10-1003 \$23.21

Fire Resistant Neck Gaitor/Face Mask

Made with DuPont™ Nomex® and elastomer, BUFF® Fire Resistant multifunctional headwear is certified as Personal Protective Equipment under standards EN ISO 13688/13, EN ISO 11612/15 and EN1149-5/08. Product certified according to the UNE-EN 15614/07 Wildland Firefighting clothing standard.

- Made with fire-resistant DuPont™ Nomex® material
- Multifunctional - can be worn as a neck gaitor, face mask, cap, balaclava, etc.
- 100% seamless construction
- One-size-fits-all adults

Part # 345-72-10-1005 \$21.00



Hot Shield Facemask

The Hot Shield Model HS-2 Wildland Firefighter Face Mask is a patented, highly flame resistant face protector designed by firefighters for use in all wildland firefighting operations. The HS-2 offers the extreme protection against burns to the face/neck with the added benefit of blocking and reducing the inhalation of smoke & ash particulate.

Filter: N95 with exhalation valve.

Limitations: This type of filter doesn't block fire gases, like carbon monoxide, so don't assume you can advance further into the fire. Use your head, training and common sense. Throw it away and replace with a new one when filter becomes difficult to breathe through or becomes damaged.



Facemask	345-72-10-1001	\$62.55	
Filter	345-72-10-1002	\$2.50	(LIMIT: 2/MASK)



FIRE RESISTANT CLOTHING



Gloves, Forest Worker

Heavy-duty, Gunn-cut, rough-out cowhide gloves are designed for use on fire lines and can be used for general forestry work. Each glove features an adjustable wrist strap. NFPA 1977 compliant. Forest Service Spec 6170-5.

Size	Part #	Price
Small	340-34-00-1000	\$21.41
Medium	340-34-00-2000	\$21.41
Large	340-34-00-3000	\$21.41
X-Large	340-34-00-4000	\$21.41

Gloves, Knit Cuff

Heavy duty, Gunn-cut, split-cowhide leather gloves are designed for use on fire lines and can be used for general forestry work. Features a wing thumb, continuous index finger construction, elastic Kevlar knit wristlet and storage strap. Anatomically designed and unlined. NFPA 1977 compliant.

Size	Part #	Price
Small	340-34-01-1000	\$26.80
Medium	340-34-01-2000	\$26.80
Large	340-34-01-3000	\$26.80
X-Large	340-34-01-4000	\$26.80



SAFETY



Goggles, Low Profile

This goggle offers a high level of comfort, protection and performance, with premier design, materials and technology. Low-profile wrap-around style in a soft polypropylene/ elastomer body conforms for an excellent, gap-free fit and provides a full field of vision. These goggles are idea for impact, chemical splash and optical radiation (99.9% UV protection). Meets ANSI Z87+ standard, ANSI.Z.87.1/1989, CA 19,072 and CSA Z94.3
For impact only—NOT RATED FOR FIRE USE

Part # 345-64-30-3960 \$9.25

Goggles, NFPA

Wildland fire scratch-resistant goggle. Sealed dual UV absorbing polycarbonate lens; anti-fog on the inside/anti-scratch on the outside. Non-vented body lined with a soft closed cell foam seal for a snug fit allowing no smoke, liquids or contaminants from entering. High temperature resistant. Fits over some prescription eyewear. Meets ANSI Z87.1 plus High Impact Standards and CUL. Manufactured to NFPA 1977-2016 edition. They provide 100% UVA/UVB protection and distortion-free optical clarity.



Part # 345-64-30-0222 \$47.15



Hard Hat, Cap

These wildfire helmets are specifically engineered to meet the special needs of wildland/forestry firefighters. Manufactured from heat-resistant thermoplastic for superior impact and penetration protection, Wildfire helmets meet and exceed the performance specifications of NFPA 1977-2005.

Features include: Easy to adjust Flex-Gear® ratchet sizing suspension, Thermoplastic shell, Reflective lime-yellow stripes, Three goggle clips, Adjustable chinstrap, Comfortable 6-point ratchet suspension, Leather ratchet cover, Absorbent cotton brow pad, and Velcro attachments inside shell.

Color	Cap Style	Price	Full Brim	Price
Yellow	345-56-20-9042	\$46.99	345-56-30-9047	\$51.46
White	345-56-20-9045	\$46.99	345-56-30-9050	\$51.46
Red	345-56-20-9044	\$46.99	345-56-30-9048	\$51.46



Weather Belt Kit

A complete observing kit with everything needed to measure temperature, relative humidity and wind velocity. Consists of Weather Kit Case, Smoke Chaser's Compass, Wind Speed Indicator, and Sling Psychrometer (mercury-free). Also contains 1-oz. plastic Screw-Cap-Bottle, Wood Pencil, notebook, and humidity and dew-point tables. Forest Service Spec 5100-150, MEDC-531.

Part # 220-87-10-1001 \$168.52



SAFETY

Headlamp, LED

- Cree neutral white LED with a lifespan of 50,000 hours.
- Powered by one AA (alkaline/ Ni-MH) battery (included).
- Max 240 lumens and max 100 hours runtime.
- Three output levels for all kinds of lighting demands.
- Digitally regulated output maintains sectional constant brightness.
- Reverse polarity protection to protect improper battery insertion.
- One-switch control ensures easy and fast operation.
- Low-voltage warning reminds when battery replacement needed.
- Made of quality aluminum and silicone - tough and durable.



ANSI/FSC	Low	Medium	High
OUTPUT LUMENS	4	70	240
RUNTIME	100h	16h	8h*
DISTANCE	32ft (9.5m)	112ft (34m)	207ft (63m)
INTENSITY	22cd	286cd	980cd

Headlamp **345-70-70-1301** **\$26.25**



Personal Strobe

The Guardian is the lightest, brightest, toughest light in its class! Features a powerful flashing LED that is visible up to one mile. Omni-directional light can be seen from all sides with unique optics. Two modes of operation: steady-on or flashing. Just flip the batteries over to change modes! Can be attached with heavy-duty clip or through the built-in belt loops.

Approx. Battery Life:

Flashing Mode = 250 hours Steady-On Mode = 100 hours

Lithium battery included. Uses 2 CR 2032 Lithium Coin Cell Batteries.

Part # 345-70-70-1001 **\$14.65**

Personal Strobe & Flashlight

The strobe light has a built in LED flashlight to make it even more useful. The switch is magnetic and can easily be activated with gloved hands. Unit is double o ring sealed and withstands up to 130ft under water. Due to the unique nature of this module, only a clear strobe is offered. **Color is Orange.**

This unit requires 3 AA batteries which allows it to operate on strobe mode for up to 24 hours and the flashlight can run for 8 hours.

Part # 345-70-70-1002 **\$19.54**



Triangle Warning Kit

Highway Warning Triangles, Highway Rated, Length 18 In., Width 5 In., Height 4-1/2 In., Plastic Material, Orange/Red Color, Standards Meets FMVSS 125, SAE-W4-74DOT, Includes Three Warning Triangles, Storage Box

Part # 055-27-14-7862 **\$26.47**



SAFETY



Gloves, Economy

Rugged shoulder leather palm gloves are great for construction, agricultural, maintenance, and many other heavy-duty applications. Features gunn pattern, wing thumb, full leather index finger, fingertips, and knuckle strap, and elasticized cotton back. Soft palm lining keeps hands cool and comfortable

Part # 340-34-10-1001 \$2.60

Flagging; FIRE LINE—DO NOT CROSS

2.5-Mil All-weather Barricade Tape, Black Lettering
polyethylene barricade tape won't sag in hot weather or turn brittle in cold weather. 1,000' per roll, 3" wide.

Dispenser; Barricade Tape

Barricade Tape Dispenser. Holds up to 1000 foot rolls. Serrated edges cut tape quickly. Dispenses tape with ease! A breeze to use. Made in USA.

Fire Line Tape #832-48-20-1001 \$10.99
Dispenser #832-48-20-1002 \$7.15



Chainsaw Operators Helmet

Sturdy hardhat with padded, six-point suspensions, adjustable hearing protectors, and nylon visor carriers with black mesh steel screens. Components meet or exceed these ANSI Standards: hardhats, ANSI Std. Z89.1-1997 Type I, Class C, E and G; ear muffs, ANSI Std. S3.19-1974; mesh screen, ANSI Std. Z87-S 1992; visor carriers, ANSI Std. Z87.1-1997. Features a premium, ratchet-tight suspension system which adjusts for snug, comfortable fit and superior earmuffs (24 NRR*) with ultra-soft cushions.

Part # 345-56-50-1001 \$41.95



Chainsaw Chaps

These heavy-duty chaps are designed specifically to protect against chainsaw cuts. The cut-resistant nylon duck shells are padded with five layers of aramid fillers. Chaps cover front and sides of legs from waist to mid-calf and are secured with adjustable waist belt and leg straps. The orange color will aid in visibility and assist users in determining when the chaps require cleaning. For proper fit, length should be selected to cover from the user's waist to at least 2" below boot top. Features a tool pouch. Forest Service Spec 6170-4G

Length	Part #	Price
32"	345-64-15-0032	\$173.92
36"	345-64-15-0036	\$173.92
40"	345-64-15-0040	\$173.92



SAFETY

Fire Shelter, Regular

New-generation fire shelter provides increased protection from radiant and convective heat in wildland firefighter entrapment situations. This set includes: fire shelter, nylon duck carrying case, carrying case plastic liner. Deployed size: 86" long; 15-1/2" high; 31" wide. Forest Service Spec 5100-606.

Part # 345-24-10-0925 \$426.78



Fire Shelter, Large

New-generation fire shelter provides increased protection from radiant and convective heat in wildland firefighter's entrapment situations. Large-size shelter designed for firefighters taller than 6'1" or whose girth exceeds 53" at any point. The larger fire shelter provides better protection for larger people by allowing less contact of the shelter material with the occupant's body, and it provides more air space between the shelter and occupant. The large fire shelter is easily identified by the orange deploy strap. This set includes: fire shelter, nylon duck carrying case and carrying case plastic liner. Deployed size: 96" long; 19-1/2" high; 33" wide. Forest Service Spec 5100-606.

Part # 345-24-10-0975 \$537.58



Practice Shelter, Regular

Reusable practice fire shelter system for training in use of fire shelter. Same size and dimensions as fire shelter. Includes the carrying case, case liner, polyvinyl bag, and practice shelter. Note: This item is not fire-resistant and should not be used as a fire shelter. Forest Service Spec 5100-611.

Part # 345-24-20-2678 \$147.55



Practice Shelter, Large

Reusable practice fire shelter system for training in use of large fire shelter. Large-size shelter designed for firefighters taller than 6'1" or whose girth exceeds 53" at any point. Same size and dimensions as Large fire shelter. Includes the carrying case, case liner, polyvinyl bag, and practice shelter. Note: This item is not fire-resistant and should not be used as a fire shelter. Forest Service Spec 5100-611.

Part # 345-24-20-2799 \$168.63



Replacement Bag for Practice Shelter

Reusable polyvinyl bag for M-2002 practice fire shelter. Simulates the tear-open bag used with the real fire shelter. Polyvinyl bag only. Practice fire shelter, carrying case, and carrying case liner are sold separately. **Fits regular and Large practice shelters.** Forest Service Spec 5100-611.

Part # 345-24-25-2681 \$35.33



SAFETY

Safety Vest, Fire Resistant—*FOR DNR PURCHASE ONLY.*

Class 2 safety tear away adjustable safety vest. Fire resistant (meets ANSI-ISEA-107-2004). Includes left front chest pocket, right & left front mic loop.



Size	Part #	Price
Small/Medium	345-92-20-1001	\$11.50
Large/XLarge	345-92-20-1002	\$11.50
2X/3X-Large	345-92-20-1003	\$11.50



Safety Vest, ANSI Class II

ANSI-ISEA 107-2010 Class 2 Lime Vest with orange contrasting 3M Scotchlite Reflective stripes, inside pockets, zipper front closure.

Safety Vest, ANSI Class II—ONE SIZE FITS MOST

ANSI-ISEA 107-2010 Class 2 Lime Vest with orange contrasting 3M Scotchlite Reflective stripes, inside pockets, zipper front closure. 5pt Tear away.

THIS VEST IS REPLACING THE SINGLE SIZED VESTS AS STOCK IS DEPLETED.

Size	Part #	Price
Medium	345-92-10-2000	\$12.20
Large	345-92-10-0000	\$10.00
X-Large	345-92-10-0000	\$10.00
2X-Large	345-92-10-0000	\$10.00
3X-Large	345-92-10-6000	\$13.63
4X-Large	345-92-10-7000	\$14.67

Wheel Chock

Heavy duty rubber wheel chock with chain eye. Measures 10"L x 8"W x 6"T and weighs 8.25 lbs.

Part #075-56-32-1001 \$22.00



Padlock, Keyed Alike—*FOR DNR PURCHASE ONLY.*

- Commercial grade padlock features superior protection from drilling and prying
- 1-3/4" (44mm) wide laminated steel body for superior strength
- 15/16" (24mm) tall, 5/16" (8mm) diameter hardened steel shackle for superior cut resistance
- Dual locking levers provide extra pry resistance
- Non-rekeyable, 4-pin W1 cylinder helps prevent picking

#2797 450-55-20-2797 \$10.00

#X2840 450-55-20-2840 \$10.00



SAFETY



Traffic Cone

Tough, weatherproof orange PVC traffic cones have a tip-resistant, weighted base. Maintenance-free, non-fading PVC resists peeling, cracks and moisture. Includes one 6" and one 4" reflective collar. Meets MUTCD standards. 28"T

Part # 550-78-27-1001 \$27.31

Traffic Cone; Collapsible 4/PK

Each 28" collapsible cone has a 6" and 4" reflective collar and the internal battery powered LED light (two AA batteries required) has two settings – Steady-On or Flash. Rubber feet help resist moving from high winds or passing cars. Four pack with carrying/storage case.

Part # 550-78-27-2804 \$124.98



Bracket, Traffic Cone

Horizontal mount traffic cone holder. Holds up ten 18" cones or five 20" cones.

Part #999-90-99-4000 \$23.75



SAFETY

First Aid Kit, Loggers Type

DNR approved loggers type first aid kit. Enclosed in water tight case. **Includes SOF® Tactical Tourniquet-Wide.**

First Aid Kit 345-32-10-1000 \$80.00
 Tourniquet 345-32-20-1001 \$25.47



FIRST AID KIT CONTENTS			
PART #	QTY	DESCRIPTION	PRICE/EA
345-32-20-1002	20	1" X 3" BANDAGE - LATEX FREE	\$0.05
345-32-20-1003	10	FINGERTIP FLEX FABRIC BANDAGE	\$0.10
345-32-20-1004	10	KNUCKLE FLEX FABRIC BANDAGE	\$0.09
345-32-20-1005	10	2" X 4" BANDAGE - LATEX FREE	\$0.16
345-32-20-1006	2	TRIANGULAR BANDAGE W/PINS	\$.96
345-32-20-1007	1	SAM® SPLINT JUNIOR - 18"	\$8.50
345-32-20-1008	10	ANTISEPTIC WIPE	\$0.05
345-32-20-1009	1	RESCUE BLANKET - 52" X 84"	\$1.90
345-32-20-1010	1	TRANSPORE TAPE, 1" X 10 YDS	\$1.64
345-32-20-1011	1	CPR MICROSHIELD® - DISPOSABLE	\$6.81
345-32-20-1012	2	ELASTIC BANDAGE (ACE) 2" X 5 YD	\$0.80
345-32-20-1013	1	TWEEZERS, STAINLESS STEEL	\$1.93
345-32-20-1014	2	GLOVES, LATEX FREE - 1 PAIR, BAGGED	\$0.65
345-32-20-1015	5	GAUZE PADS 4" X 4" - 12 PLY	\$0.14
345-32-20-1016	1	CONFORMING BANDAGE, 2" X 6 YD	\$2.42
345-32-20-1017	1	SCISSORS, EMT, METAL 5-1/2"	\$2.81
345-32-20-1018	2	TRAUMA PAD - 8" X 10"	\$0.93
345-32-20-1001	1	TOURNIQUET	\$25.47

Wipe; Fire Decontamination

Firewipes' On-Scene Firefighter Skin Decontamination Wipes help clean soot, smoke, and other potential carcinogens of complete and incomplete combustion off the skin. The 8" x 12" textured industrial strength disposable wipes are infused with cleansing compounds for use on all external dermal areas. The wipes are also saturated with a unique formula specifically designed to minimize additional carcinogenic exposure through dermal absorption.



Part # 735-60-93-1001 \$1.15 each



SAFETY

Ear Plugs

Ear Plugs, Without Cord, Noise Reduction Rating NRR 32dB, Plug Color and style may vary from picture. Plug material polyurethane packaged in poly bags. Standards ANSI S3.19-1974, Package Quantity 200

345-90-22-1001 \$17.50



Gas Can, Type I Safety

Type I safety can used to store, transport, and dispense flammable liquids safely; has single spout for filling and pouring. Made of galvanized steel, which is resistant to rust, dents, and certain chemicals; red powder-coated finish resists scratches, chipping, fading, and other wear. Stainless steel flame arrester helps prevent liquids inside the can from igniting and keep flames from spreading. FM Approved; complies with OSHA Standard 1910.106 for the safe storage and handling of flammable liquids.

Size	Part #	Price	O.D.
1 gal.	450-17-10-1000	\$58.80	7.25"
2 gal.	450-17-10-2000	\$52.80	11.75"
5 gal.	450-17-10-5000	\$57.99	11.75"

Tow Strap

High quality, heavy duty nylon tow straps are ideal for towing and freeing trucks or disabled vehicles from mud, sand or snow. They feature ends protected with cordura for maximum protection. Straps are 20 feet long.

WLL	Part #	Price	Width
20,000#	450-21-96-2000	\$65.52	2"
40,000#	450-21-96-4000	\$110.34	4"



Anchor Shackle

Anchor shackles are safety screw type, galvanized.

5/8—5 Ton 450-19-70-0058 \$33.22 (for use with 20,000# strap)
 7/8—9.5 Ton 450-19-70-0078 \$61.31 (for use with 40,000# strap)



PACKS & COMPONENTS



Field Pack, Complete

Most versatile Fire Pack on the market. Our load swallowing 2200 cu in gear bag, combined with the trap pocket and lash down loops, means you can take it all with you when you're working the line. With two quick zips you can drop the gear bag and carry just the essentials - 100oz. hydration reservoir, fire shelter, fuses, and all the gear you can stuff in the 300 cu in stash pocket. So whether you're working near equipment or out in the wilderness, the Firefly does it all.

Part # 530-25-15-1001 \$242.21

Equipment Belt

Nylon web belt attaches to harness for added support and comfort when carrying a fire shelter. Serves as a replacement belt for the old style Complete Firefighter's Field Pack NSN 8465-01-169-3996. Forest Service Spec 5100-217.

Part # 530-25-10-1004 \$10.99



Harness, Field Pack

Comfortable, padded harness is a replacement for the harness included in the old style Complete Field Pack NSN 8465-01-169-3996. Harness is adjustable so that it may be worn by men or women. Used with equipment belt for added support to carry fire shelter. Forest Service Spec 5100-217.

Part # 530-25-10-1003 \$11.99

Belt Pack

Nylon duck belt pack replaces the belt pack included in the Complete Field Pack NSN 8465-01-169-3996. With two straps to attach to belt. Forest Service Spec 5100-217.

THIS ITEM HAS BEEN DISCONTINUED. LIMITED AVAILABILITY.

Part # 530-25-10-1001 \$9.49



Canteen Case, Field Pack

Replacement canteen case for the Complete Field Pack NSN 8465-01-169-3996. Canteen is made of nylon duck and webbing. Forest Service Spec 5100-217. ***THIS ITEM HAS BEEN DISCONTINUED. LIMITED AVAILABILITY.***

Part # 530-25-10-1002 \$10.50



PACKS & COMPONENTS

Pack, Personal Gear

Heavyweight, urethane-coated nylon duck pack carries up to 40 lbs. of gear. Styled with a main compartment, a sleeping bag compartment, and front and back pockets. Features adjustable shoulder straps that hide away in back pocket and buckles that allow pack to be attached to a firefighter's field pack. Includes carrying handle on side of bag. Forest Service Spec 5100-215.

Part # 530-25-20-1001 \$57.25



Pack, Tent

Personal gear pack tent bag is designed to hold a one-person tent that compacts into a 28 x 5" size (tent not included). For attachment to Personal Gear Pack NSN 8465-01-141-2321. Forest Service Spec 5100-215B.

Part # 530-25-20-1002 \$34.30

Briefcase

All-purpose case is made of sturdy nylon Cordura. Features a single inner compartment, pockets on each side, and a shoulder strap.

Part # 530-25-20-1004 \$33.50



Radio Chest Pack, Pack Shack, Black

Adjustable top strap makes this chest pack fit most radio sizes. Includes battery pouch, map pocket and pen holder. Our chest pack comes with a solid fabric back with 1/8" foam to provide padding between your chest and the radio. Chest packs are 10"x10" and have a side opening map pocket. One inch nylon straps cross in back for easy adjustment. **Color is black** (pictured in blue to show detail)

Part # 530-25-25-1002 \$69.90

Radio Chest Pack, True North

True North Radio Chest Dual Universal Harness is designed for greater comfort and function. Our radio harness sits comfortably on your chest, without sagging or swinging, due to unique suspension system. Elastic straps keep radios in place when bending over. Adjustable pocket holds a mobile phone or GPS unit. Mesh back plate allows airflow and eliminates multiple straps. Pocket for writing tools, penlight, and other instruments. Large map / notebook pocket with velcro closure. Pocket for spare battery or small mobile phone.

Part # 530-25-25-1001 \$65.15



PACKS & COMPONENTS

Tool Bag; Tanker Style—Large

Military style tanker tool bag is constructed of a durable, heavyweight cotton canvas material. It measures 19" x 9" x 6. Perfect for protecting a 40,000lb tow strap.

Part # 999-00-90-1020 \$15.99



Tool Bag; 2-Bag Combo

This custom 2 bag combo is made of durable polyester fabric and features a large interior. They open wide for easy access to the bag's contents. Includes one medium bag (14" x 5-1/2" x 6") and one small bag (12" x 4-1/2" x 5-1/2").

Part # 999-00-90-1021 \$24.00

Field Pack, Pack Sack (REPLACES GREEN PACK SACK)

Intended for use in a wide variety of field-related activities, including wildland fire suppression. Large main compartment with storm flap, drawstring closure. Two side pockets, one large front pocket with zippered closure. Reinforced padded shoulder straps with quick release waist strap. Dimensions: 19 x 18 x 8

Part # 530-25-20-1005 \$41.80



CANTEENS, COOLERS & PAILS



Canteen, 1 Qt.

Rigid plastic water bottle with cap is rectangular and disposable. Measures 2-1/2 x 3-3/4 x 8-1/4" overall.

Canteen Only **450-87-46-0100** **\$2.15** (carrying case available on page 27)

Canteen, 4 Qt.

For carrying water, this canteen features a chained screw cap and an adjustable over-the-shoulder carrying strap. It is made of polyethylene plastic and the sides are covered by polycarbonate disks for protection against punctures and abrasion.

Part # 450-87-33-0400 **\$13.21**



Water Cooler, 5 Gal.

Jug is for cold liquids and features a self-closing faucet. Not for use with milk or milk products. Leakproof inner and outer shells form an insulating space. Maintains contents' original temperature for approximately four hours. With plastic outer shell, plastic cover/stopper and urethane foam insulation (CFC free); faucet guarded. With seamless plastic inner shell Meets FDA requirements.

Part # 450-87-09-0500 **\$53.35**

Pail, Collapsible

Round, collapsible pail is made of vinyl-coated nylon scrim. With a stiffened and reinforced top rim. Approximate size is 9" in diameter and 11" high. High tensile strength. Leak-proof seams. Withstands up to 100 psi hydrostatic pressure.

Part # 450-87-20-0300 **\$10.75**



HOSE, FITTINGS & ACCESSORIES



Booster Hose, Rubber

Hose is rubber with a spiral braid nylon reinforcement layer. Working pressure is 200 PSI and weight is 34 pounds per 100 ft for 3/4" and 54 pounds per 100 ft for 1".

Size/I.D.	Part #	Price
3/4"	340-56-15-0750	\$1.96/ft
1"	340-56-15-1000	\$2.90/ft
1" x 100' w/NH couplings	340-56-15-1010	\$322.50

Booster Hose, Lightweight, 1" x 100ft

Kink resistant, even at low pressure. The bend radius is less than 4 1/2" for a 1.0" hose. It is non-collapsible and fits standard hose reels and has heavy duty spun yarn construction and premium all synthetic single jacket. Jacket is treated against abrasion, moisture pick up and mildew. It is also resistant to most chemicals, petrol products, ozone and U.V. exposure, and hydrolysis. Sold in 100ft lengths. 1" NH couplings. Working pressure-300 PSI, service test pressure-600 PSI. Weight is 24 lbs.

Part # 340-56-10-1100 \$310.95



Discharge Hose, 3/4" x 50ft

Lightweight hose features a woven synthetic jacket and is lined. The 5/8"-diameter hose features 3/4" standard garden hose threads. Operating pressure is 200 psi.

Part # 340-56-20-7505 \$48.94

Discharge Hose, 1" & 1-1/2"

Meets or exceeds NFPA 1961 and forestry spec 5100-187 standards. Type I hose is lighter in weight and has a smaller coiled diameter. Type II hose is more abrasion resistant, heavier in weight and produces a larger coiled diameter. NH Couplings.

Size	Type I	Price	Type II	Price
1" x 50'	340-56-20-1005	\$78.20	340-56-22-1005	\$77.95
1" x 100'	340-56-20-1010	\$117.45	340-56-22-1010	\$128.55
1-1/2" x 50'	340-56-20-1505	\$81.50	340-56-22-1505	\$97.25
1-1/2" x 100'	340-56-20-1510	\$133.15	340-56-22-1510	\$164.10



Suction Hose, 1-1/2" & 2-1/2"

PVC lightweight fire suction hose. Clear and flexible to allow visual monitoring, smooth bore for unrestricted flow, operates in extreme temperatures, and is very flexible. For drafting only. Meets or exceeds all NFPA requirements for fire hose, current edition. NH couplings.

Size	1-1/2"	Price	2-1/2"	Price
Bulk, Per Foot	340-56-30-1500	\$4.26	340-56-30-2500	\$6.50
5' w/Couplings	340-56-30-1505	\$29.10		
6' w/Couplings			340-56-30-2506	\$54.88
9' w/Couplings	340-56-30-1509	\$55.59	340-56-30-2509	\$63.52



HOSE, FITTINGS & ACCESSORIES



Hose thread Reducers, Increases and Adapters

Aluminum, forestry type fitting. Used to reduce, increase, or adapt thread size.

GHT—Garden Hose Thread

NPT—National Pipe Tapered Thread (standard pipe thread)

NH—National Hose Thread (also known as NST)

NPSH—National Pipe Straight Hose Thread (commonly used by USFS)

Part #	Description	Price
340-56-60-3410	3/4" F-GHT X 1" M-NH	\$8.50
340-56-61-3434	3/4" F-GHT X 3/4" M-NPT	\$9.75
340-56-74-3410	3/4" F-NPT X 1" M-NH	\$7.80
340-56-62-3434	3/4" M-GHT X 3/4" M-NPT	\$7.85
340-56-77-1010	1" F-NPSH X 1" M-NH	\$19.09
340-56-76-1034	1" F-NPSH X 3/4" M-GHT	\$7.50
340-56-74-1010	1" F-NPT X 1" M-NH	\$15.23
340-56-73-1034	1" F-NPT X 3/4" M-GHT	\$7.80
340-56-71-1010	1" F-NH X 1" M-NPSH	\$12.50
340-56-67-1010	1" F-NH X 1" M-NPT	\$8.81
340-56-64-1010	1" F-NH X 1" M-NH	\$7.75
340-56-64-1015	1" F-NH X 1-1/2" M-NH	\$10.65
340-56-63-1034	1" F-NH X 3/4" M-GHT	\$15.68
340-56-72-1010	1" M-NH X 1" M-NPSH	\$8.75
340-56-70-1010	1" M-NH X 1" M-NPT	\$16.59
340-56-65-1515	1-1/2" DBL F-NH SWIVEL	\$14.02
340-56-66-1515	1-1/2" DBL M-NH	\$17.52
340-56-77-1510	1-1/2" F-NPSH X 1" M-NH	\$11.40
340-56-78-1515	1-1/2" F-NPSH X 1-1/2" M-NPT	\$17.78
340-56-77-1515	1-1/2" F-NPSH X 1-1/2" M-NH	\$18.57

Part #	Description	Price
340-56-75-1515	1-1/2" F-NPT X 1-1/2" M-NPSH	\$15.62
340-56-74-1515	1-1/2" F-NPT X 1-1/2" M-NH	\$20.79
340-56-64-1510	1-1/2" F-NH X 1" M-NH	\$20.14
340-56-69-1515	1-1/2" F-NH X 1-1/2" F-NPT	\$10.00
340-56-67-1515	1-1/2" F-NH X 1-1/2" M-NPT	\$15.62
340-56-64-1525	1-1/2" F-NH X 2-1/2" M-NH	\$12.18
340-56-63-1534	1-1/2" F-NH X 3/4" M-GHT	\$16.28
340-56-70-1515	1-1/2" M-NH X 1-1/2" M-NPT	\$17.72
340-56-77-2015	2" F-NPSH X 1-1/2" M-NH	\$9.65
340-56-77-2020	2" F-NPSH X 2" M-NH	\$17.91
340-56-77-2025	2" F-NPSH X 2-1/2" M-NH	\$19.00
340-56-74-2015	2" F-NPT X 1-1/2" M-NH	\$18.50
340-56-74-2025	2" F-NPT X 2-1/2" M-NH	\$16.50
340-56-65-2525	2-1/2" DBL F-NH SWIVEL	\$40.43
340-56-66-2525	2-1/2" DBL M-NH	\$21.17
340-56-74-2525	2-1/2" F-NPT X 2-1/2" M-NH	\$11.30
340-56-64-2515	2-1/2" F-NH X 1-1/2" M-NH	\$17.45
340-56-67-2525	2-1/2" F-NH X 2-1/2" M-NPT	\$19.50
340-56-70-2525	2-1/2" M-NH X 2-1/2" M-NPT	\$18.25
340-56-69-2525	2-1/2" F-NH X 2-1/2" F-NPT, SWIVEL	\$32.75

Cap with Chain

Aluminum hose thread cap with chain. Available 1, 1-1/2, and 2-1/2" sizes. All threads are NH. **NPSH thread or brass NH caps available by request.**

Size	Part #	Price
1"	340-56-79-1000	\$16.99
1-1/2"	340-56-79-1500	\$21.19
2-1/2"	340-56-79-2500	\$27.49



HOSE, FITTINGS & ACCESSORIES



Hose Couplings, Expansion Rings, & Gaskets

Meets USDA Forest Service Spec 5100-108. Expansion Rings are made from seamless soft anneal red brass tubing for maximum expansion without danger of breaking. Chamfered edge prevents cutting of hose. All couplings are NST thread. Male couplings include tail gasket and Female couplings include face gasket and tail gasket.

Pictured parts from left to right: expansion ring, tail gasket, male coupling, face gasket, female coupling, tail gasket, expansion ring

Description	Female NH	Price	Male NH	Price
1" X 1-3/16" BOWL	340-12-10-1188	\$10.00	340-12-11-1188	\$7.00
1" X 1-1/4" BOWL	340-12-10-1250	\$10.00	340-12-11-1250	\$7.00
1" X 1-5/16" BOWL	340-12-10-1313	\$10.00	340-12-11-1313	\$7.00
1" X 1-3/8" BOWL	340-12-10-1375	\$10.00	340-12-11-1375	\$7.00
1" X 1-1/2" BOWL	340-12-10-1500	\$10.18	340-12-11-1500	\$7.00
1-1/2" X 1-11/16" BOWL	340-12-15-1689	\$12.00	340-12-16-1689	\$10.00
1-1/2" X 1-3/4" BOWL	340-12-15-1750	\$12.00	340-12-16-1750	\$10.00
1-1/2" X 1-7/8" BOWL	340-12-15-1875	\$12.00	340-12-16-1875	\$10.00
1-1/2" X 1-15/16" BOWL	340-12-15-1938	\$12.00	340-12-16-1938	\$10.00
1-1/2" X 2" BOWL	340-12-15-2000	\$12.00	340-12-16-2000	\$10.00
1-1/2" X 2-1/16" BOWL	340-12-15-2063	\$12.00	340-12-16-2063	\$10.00
1-1/2" X 2-3/16" BOWL	340-12-15-2188	\$12.00	340-12-16-2188	\$10.00
2" x 2-3/8" BOWL	340-12-20-2375	\$15.00	340-12-21-2375	\$12.00
2-1/2" X 2-5/16"	340-12-25-2313	\$18.00	340-12-26-2313	\$15.00
2-1/2" X 2-13/16"	340-12-25-2813	\$17.00	340-12-26-2813	\$15.00
2-1/2" X 2-7/8"	340-12-25-2875	\$17.00	340-12-26-2875	\$15.00
2-1/2" X 2-15/16"	340-12-25-2938	\$17.00	340-12-26-2938	\$15.00
2-1/2" X 3-1/8"	340-12-25-3125	\$17.00	340-12-26-3125	\$15.00

Part #	Description	Price
340-12-50-0100	EXPANSION RING, 1"	\$1.50
340-12-50-0150	EXPANSION RING, 1-1/2"	\$2.00
340-12-50-0175	EXPANSION RING, 1-3/4"	\$2.25
340-12-50-0200	EXPANSION RING, 2"	\$2.01
340-12-50-0250	EXPANSION RING, 2-1/2"	\$1.95
340-12-50-0300	EXPANSION RING, 3"	\$2.00

Description	Face	Price	Tail	Price
GASKET, 1"	340-12-60-0100	\$ 1.25	340-12-65-0100	\$ 1.00
GASKET, 1-1/2"	340-12-60-0150	\$ 1.50	340-12-65-0150	\$ 1.50
GASKET, 2-1/2"	340-12-60-0250	\$2.00	340-12-65-0250	\$2.00



Hose Coupling, 1" NH X 3/4"

These couplings are a good alternative to expansion type couplings. Made of lightweight aluminum. Fits our 3/4" rubber booster hose and provides a 1" NH end which eliminates the need for an adapter. Sold as a set only.

Part #340-12-07-11188 \$82.29



HOSE, FITTINGS & ACCESSORIES

Nozzle, Lexan

Barrel-type plastic polycarbonate nozzle adjusts from straight stream to fog to off. Rubber bumper and gasket included. Available in 1" or 1-1/2" NH thread.

	3/4"		1"		1-1/2"	
Nozzle	340-64-10-0750	\$14.93	340-64-10-1000	\$12.57	340-64-10-1500	\$12.06
Gasket	340-64-50-0750	\$1.09	340-64-50-1000	\$2.08	340-64-50-1500	\$1.50



Nozzle, Ranger

These durable, lightweight firefighting nozzle are constructed of hard coated aluminum with brass and stainless steel internal components. A bumper provides protection and makes stream selection much easier, especially with gloves. The bumper is equipped with teeth which gives a more solid fog pattern than standard nozzles. Dual Range fire hose nozzles are adjustable to straight stream, fog patterns, and to on/off position. Available in 1" or 1-1/2" NH thread.

	1" NH		1-1/2" NH	
Nozzle	340-64-20-1000	\$70.77	340-64-20-1500	\$55.24
Gasket	340-64-50-1001	\$1.09	340-64-50-1501	\$1.50

Nozzle, Quad

The quad nozzle offers 4 different spray volumes. It is a simple rotation of the knurled red band. This is a straight bore nozzle with 4 different diameter orifices: 5/16", 1/4", 3/16" and 1/8". It is available in 1-1/2" NH thread. It can be converted to 1" NH using the low profile adapter listed below.

Nozzle, 1-1/2"	340-64-30-1500	\$50.49
Adapter, 1"	340-64-30-1000	\$26.96



Nozzle, Foam

These air aspirating nozzles are manufactured from the latest engineering grade composite polymers for resilience and durability on the fire scene. They are available in 2 flow rates. The 3/4" nozzle has garden hose threads and flows 8 gpm. The 1-1/2" nozzle has NH threads and flows 15 gpm.

3/4"	340-64-40-0340	\$17.37
1-1/2"	340-64-40-1500	\$37.00



HOSE, FITTINGS & ACCESSORIES

Valve, Gated Wye

Aluminum wye valve has a female inlet and two ball valved male outlets. Ball-type release of water either or both outlets. Working pressure is 600 psi. Forest Service Spec 5100-380 All threads are NH.



Size	Part #	Price
1" x 1" x 1"	340-88-10-1010	\$211.20
1-1/2" x 1-1/2" x 1-1/2"	340-88-10-1515	\$154.39
2-1/2" x 1-1/2" x 1-1/2"	340-88-10-2515	\$248.40



Valve, Thief

Aluminum alloy tee issues 600 psi maximum operating water pressure. Forest Service Spec 5100-107. Connects 1-1/2" NH female threaded inlet to 1-1/2" NH discharge and 1" H branch with male threads. Branch output regulated with a screw-type valve.

Part # 340-88-30-1510 \$74.98

Valve, Shut-off

Aluminum valve has a female threaded inlet with gasket recess and male threaded outlet. Features an on-off or open-close lever with stops at both positions. Removable inlet or outlet allows for easy cleaning and repair. With a 600 psi rating. Forest Service Spec 5100-238. All threads are NH.



1" 340-88-20-1000 \$132.31
 1-1/2" 340-88-20-1500 \$111.75



Pond Strainer w/ Foot Valve

Opens and closes automatically when you start and stop drafting water. Allows full flow for capacity but when you stop pumping it closes automatically and keeps the pump primed by preventing water from flowing out. 2-1/2" size includes eyebolt for rope. Made of coated aluminum. NH threads.

1-1/2" 460-85-40-0150 \$90.50
 2-1/2" 460-85-40-0250 \$227.00

Suction Box

Steel suction box is powder coated and has an integrated foot valve. Available in 1-1/2" or 2-1/2" NH.

1-1/2" #999-90-50-1103 \$126.09
 2-1/2" #999-90-50-2004 \$132.49



HOSE, FITTINGS & ACCESSORIES

Wrench, Spanner

Hose coupling-type wrench is designed for use on slotted or rocker-lug couplings on Forest Service fire hoses. Spanner wrench cannot be used on pin-lugs. Made of bronze, forged brass, cast aluminum or forged aluminum. Forest Service Spec 5100-101.

Small 340-60-87-1001 \$7.08
Large 340-60-87-1002 \$8.40
Pin Type 340-60-87-1003 \$9.00



Wrench, Adjustable Hydrant

Adjustable Hydrant Wrench w/ Single Spanner Head. Style 107. Wrench will accommodate pentagon heads to 1-3/4" and square heads to 1-1/4". Single hook spanner head is designed to fit 3/4" thru 6" rocker lug or pin lug fittings.

Part # 340-60-87-1004 **\$49.97**

Wrench, Foam Pail

The Universal Foam Container Wrench allows a full 360 degree rotation without skinning knuckles. Light weight yet made with high strength aluminum makes it a perfect tool for opening most foam containers.

Part # 340-60-87-1005 **\$27.90**



Clamp, Hose Shut-off

Shut-off clamp is designed for use on single-jacket, rubber-lined fire hoses sized 1" and 1-1/2". Capable of shutting off water in a hose at 300 psi operating pressure. Lightweight and compact enough to carry in a hip pocket or on a belt loop. Forest Service Spec 5100-245.

Part # 340-06-25-1002 **\$44.02**



PUMPS & PARTS

Pump, Honda WX15

This lightweight pump is powered by the 2.5 HP GX50 mini 4-stroke engine. This pump offers exceptional performance and is great for truly portable pumping power. 1-1/2" NPT suction & discharge.

Part # 720-79-10-1000 \$472.41



-PARTS LIST ON PAGE 38-



Pump, Honda WH15X

This high pressure pump is powered by the 4 HP GX120 Industrial Engine. This pump offers exceptional performance when higher pressure is required in applications such as using sprinklers or a nozzle. 1-1/2" NPT suction & discharge.

Part # 720-79-20-0150 \$619.54

- PARTS LIST ON PAGE 39-

Pump, Honda WH20X

This high pressure pump is powered by the 5.5 HP GX160 Industrial Engine. This pump offers exceptional performance when higher pressure is required in applications such as using sprinklers or a nozzle. 2" NPT suction & discharge.

Part # 720-79-20-0200 \$688.51



- PARTS LIST ON PAGE 39-



PUMPS & PARTS

Honda WX15 Parts—**Pump Model & Serial Number Required for Parts Order**

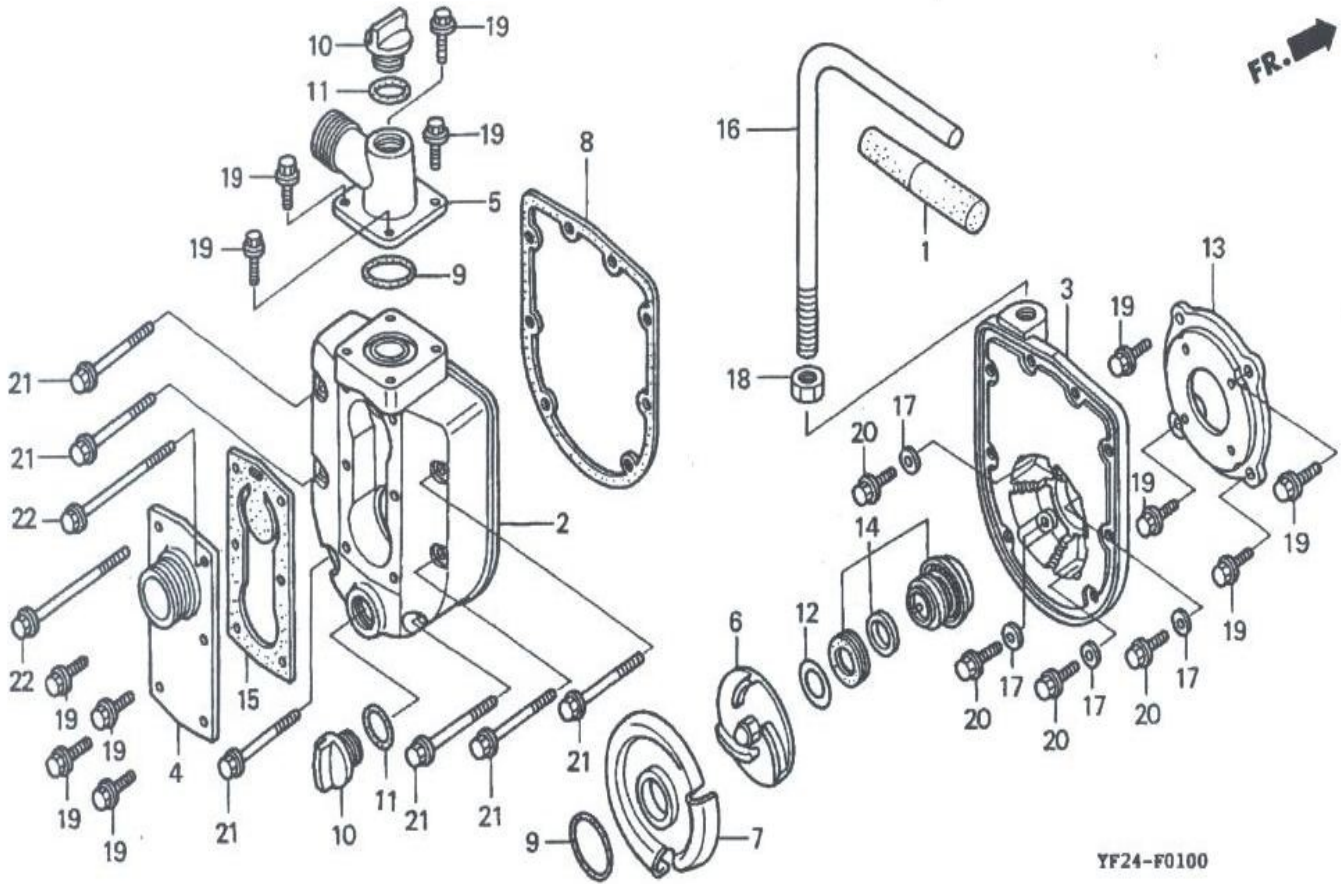

Ref	Part #	Description
1	N/A	Grip, Lever
2	720-79-10-1002	Casing
3	720-79-10-1003	Plate, End
4	720-79-10-1004	Plate, Suction-NPT
5	720-79-10-1005	Pipe, Outlet-NPT
6	720-79-10-1006	Impeller
7	720-79-10-1007	Case, Volute
8	720-79-10-1008	Gasket, End Plate
9	720-79-10-1009	Ring, Seal (A)
10	720-79-10-1010	Cap, Filler
11	720-79-10-1011	Ring, Seal (B)

Ref	Part #	Description
12	720-79-10-1012	Shim, Adjuster
13	720-79-10-1013	Case, Spacer
14	720-79-10-1014	Mechanical Seal
15	720-79-10-1015	Gasket, Suction
16	N/A	Handle
17	720-79-10-1017	Washer, Sealing-6MM
18	720-79-10-1018	Hex Nut-12MM
19	720-79-10-1019	Flange Bolt-6MM x 16
20	720-79-10-1020	Flange Bolt-6MM x 18
21	720-79-10-1021	Flange Bolt-6MM x 55
22	720-79-10-1022	Flange Bolt-6MM x 85



PUMPS & PARTS

Honda WH15X & WH20X Parts—**Pump Model & Serial Number Required for Parts Order**

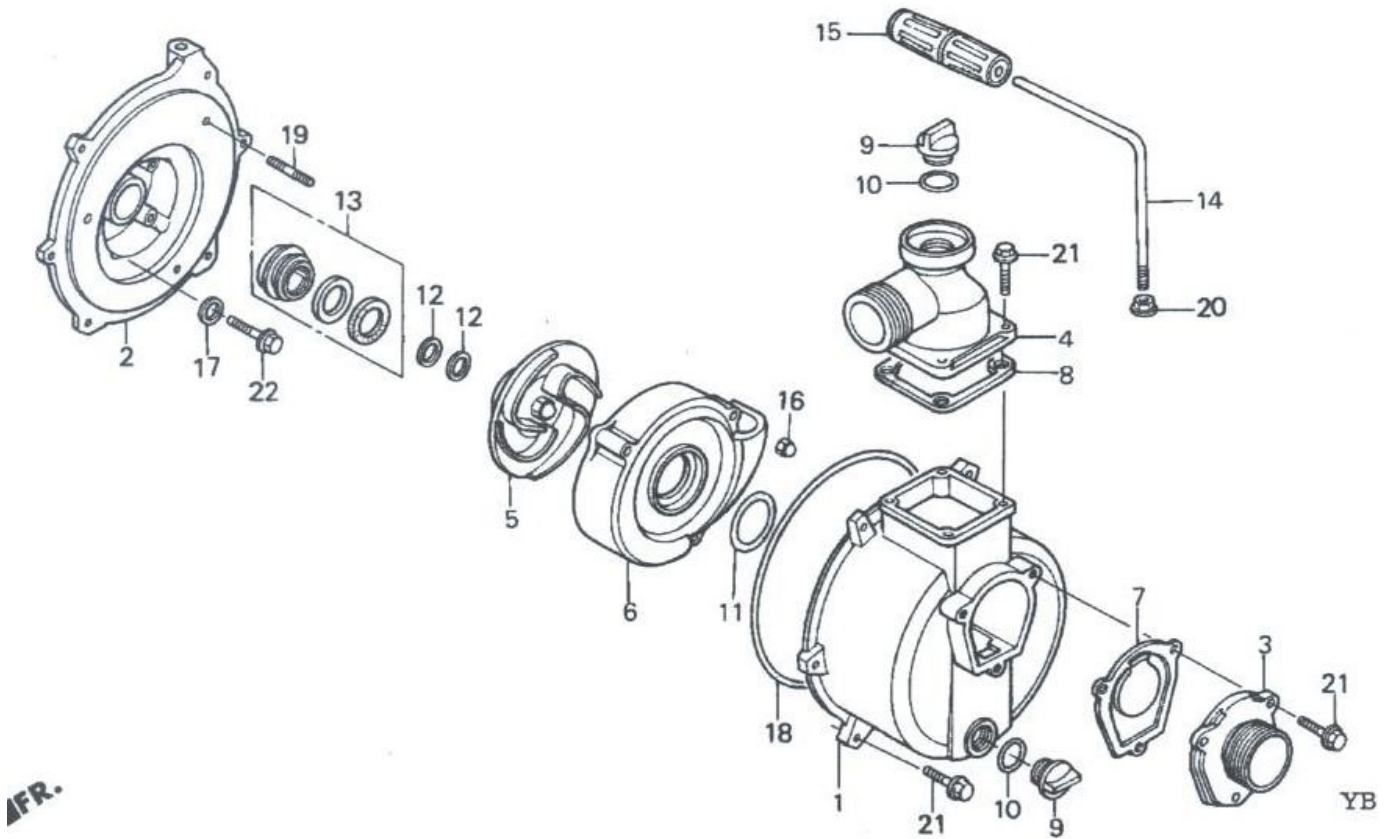

Ref	Part #	Description	Price	15X	20X
1	720-79-20-1004	Casing	\$146.50	X	X
2	720-79-20-1005	Cover, Casing	\$140.80	X	X
3	720-79-20-1017	Pipe, Inlet	\$32.75	X	
3	720-79-20-1021	Pipe, Inlet	\$78.06		X
4	720-79-20-1009	Pipe, Outlet	\$65.50	X	
4	720-79-20-1008	Pipe, Outlet	\$74.35		X
5	720-79-20-1011	Impeller	\$76.75	X	X
6	720-79-20-1018	Case, Volute	\$115.00	X	X
7	720-79-20-1006	Valve, In	\$16.25	X	X
8	720-79-20-1007	Gasket, Outlet	\$6.75	X	X
9	720-79-20-1010	Cap, Filler	\$7.90	X	X
10	720-79-20-1013	Ring, Seal (B)	\$3.41	X	X

Ref	Part #	Description	Price	15X	20X
11	720-79-20-1014	O-Ring (49 x 5.7)	\$4.95	X	X
12	720-79-20-1016	Shim, Adjuster	\$2.78	X	X
13	720-79-20-1012	Seal Assy., Mechanical	\$58.75	X	X
14	N/A	Handle	N/A	X	X
15	N/A	Grip, Handle	N/A	X	X
16	720-79-20-1002	Nut, Cap (6mm)	\$1.41	X	X
17	720-79-20-1019	Washer (8mm)	\$0.90	X	X
18	720-79-20-1015	O-Ring (217.5 x 3.5)	\$8.90	X	X
19	720-79-20-1024	Bolt 2, Stud (6mm x 35)	\$1.10	X	X
20	720-79-20-1025	Nut, Hex (14mm)	\$2.06	X	X
21	720-79-20-1026	Bolt, Flange (8mm x 25)	\$1.32	X	X
22	720-79-20-1023	Bolt, Flange (8mm x 28)	\$1.28	X	X



PUMPS & PARTS

Pump, CET with Honda Engine

A compact design pump that gives you a multitude of applications. It delivers amazing pressure performance so as to meet the needs of several application.

Dimensions: Length : 20" (508 mm); Width : 17" (432 mm); Height : 17" (432 mm).
Weight : 70lbs (32 kg)

ENGINE SPECIFICATIONS:

- * Honda GX270, air cooled engine
- * Single cylinder gasoline engine
- * Manual recoil start as backup
- * 9 hp@3600 rpm
- * Electric start
- * 1,7 gallon (6,5 L) integrated fuel tank

PUMP UNIT SPECIFICATIONS

- * C.E.T Dual Stage Centrifugal Pump
- * Aluminum impeller
- * Self priming system
- * Outlet connection: (2)1" (1) 1 ½"
- * Pump body made from aluminum
- * Mechanical shaft seal
- * Two stages
- * Inlet connection: 1 ½"

Part # 720-20-30-1001 \$2,567.75

CET Pump — PARTS LIST ON PAGE 40

Davey Pump with Honda Engine - PARTS LIST ON PAGE 42-43



Pump, Darley 2BE18V with Mechanical Seal

Medium Pressure, High Volume, Direct Drive, Engine Mounted Pump. Includes base with handles, exhaust primer, 6 gallon fuel tank, control panel, and spark arrestor. Briggs & Stratton Vanguard 4 cycle, 18 HP, V-twin, OHV, replaceable oil filter, 34.75 cu. in. displacement, 12-volt starter, recoil rope start back-up, 16 amp regulated alternator, 7.2 qt. fuel.

Dimensions: 27"L x 21"W x 25"H, 145 lbs. (66 kg)

3" NPT suction
(2) 2½"NPT and (2) 1½" NPT discharges

Part # 720-15-15-0189 \$6,709.80 + \$150.00 Freight

PUMP WITH MECHANICAL SEAL—PARTS LIST ON PAGES 44

PUMP WITH PACKING—PARTS LIST ON PAGES 45-46

Pump, Jabsco 18670-0123

Commercial duty Water Puppy pump features a bronze pump housing. The motor may be reversed for intermittent duty. The suction lift is about 6 feet (2m) when dry and about 20 feet (6m) when primed.

Part # 120-44-45-1002 \$237.99



PUMPS & PARTS

CET with Honda Engine—PFP-9hpHND-EM-TWIN

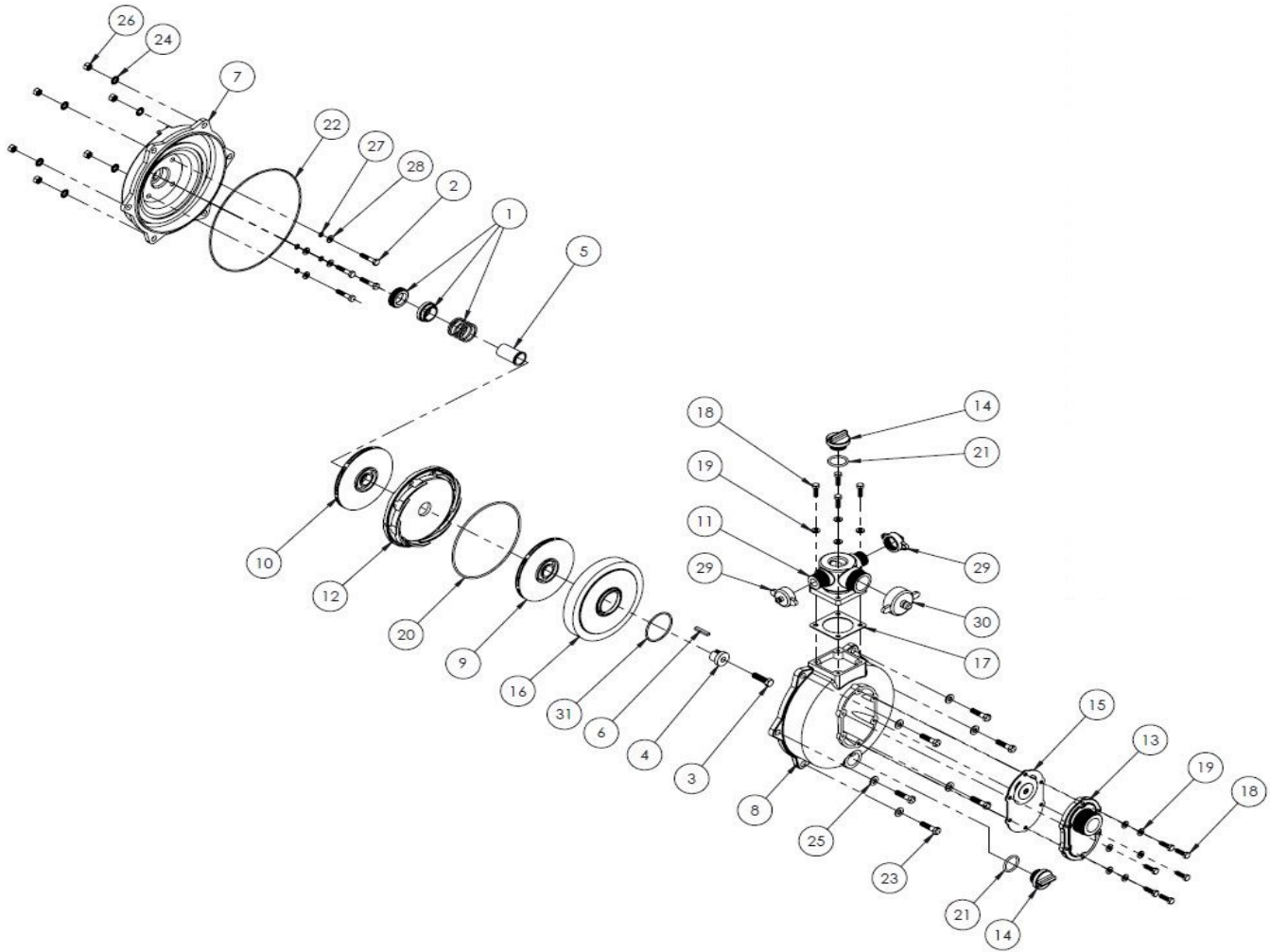

Ref	Part #	Description	Price
1	720-20-31-0390	Mechanical Seal	\$90.00
2	720-20-31-0393	Bolt; 5/16-18 x 1 3/4"	\$0.50
3	720-20-31-0036	Bolt; 7/16"-20 X 1-1/2"	\$0.50
4	720-20-31-0369	Extension (alum)	\$45.00
5	720-20-31-0370	Bushing (bronze)	\$45.00
6	720-20-31-2802	Shaft Key—1/4 x 3/16 x 1-3/8	\$1.25
7	720-20-31-0356	Rear Casing	\$160.00
8	720-20-31-0002	Casing	\$265.00
9	720-20-31-00361	Front Impeller	\$108.00
10	720-20-31-0362	Rear Impeller	\$108.00
11	720-20-31-0013	Outlet; 3-Way	\$80.00
12	720-20-31-1037	Diffuser	\$168.00
13	720-20-31-2801	Intake	\$90.00
14	720-20-31-0030	Plug	\$12.19
15	720-20-31-2803	Intake Gasket	\$20.25
16	720-20-31-1004	High Pressure Impeller Cover	\$240.00

Ref	Part #	Description	Price
17	720-20-31-0012	Outlet Gasket	\$12.50
18	720-20-31-2808	Hex Bolt	\$1.25
19	720-20-31-2809	Washer	\$0.25
20	720-20-31-2004	O-ring; Diffuser	\$6.50
21	720-20-31-0027	O-ring; Plug	\$2.75
22	720-20-31-0372	O-ring; Casing	\$11.00
23	720-20-31-0394	Bolt; 3/8"-24 X 1-1/2"	\$2.25
24	720-20-31-0032	Int Tooth Lock Washer; 3/8	\$0.25
25	720-20-31-0020	Flat Washer; 3/8	\$0.15
26	720-20-31-0396	Hex Nut; 3/8	\$0.50
27	720-20-31-0395	O-ring	\$2.25
28	720-20-31-0241	Washer; 5/16	\$0.25
29	720-20-31-0017	1 Cap	\$1.00
30	720-20-31-0014	1-1/2 Cap	\$1.50
31	720-20-31-0004	O-ring; Impeller Cover	\$4.00



PUMPS & PARTS

Davey with Honda Engine—5290HE

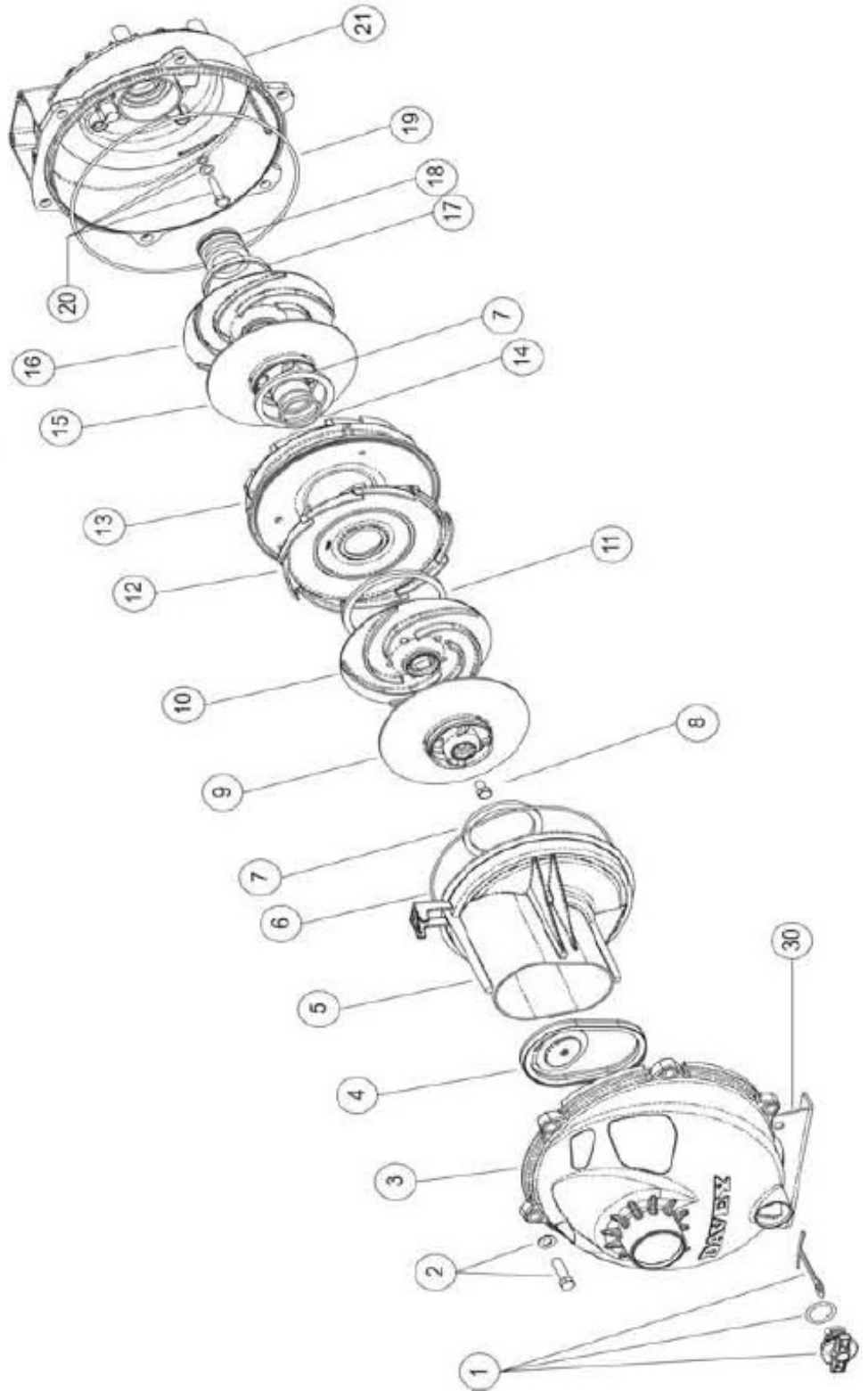
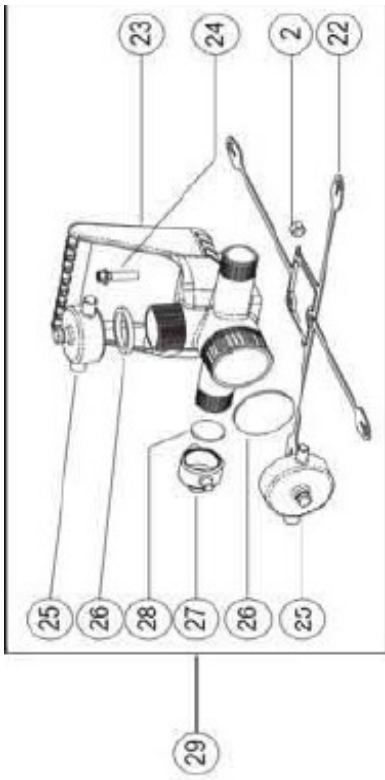

PUMPS & PARTS

Davey with Honda Engine—5290HE

Ref	Part #	Description	Vendor Part #	Price
1	720-20-25-1026	PRIMING/DRAIN PLUG ASSY.	32162	\$25.00
2	720-20-25-1003	KIT – BOLT & NUT	32163	\$8.25
3	720-20-25-1008	CASING – FRONT – 1-1/2”	13525-3PR	\$191.00
4	720-20-25-1014	FLAP VALVE ASSY.	13081-3	\$38.00
5	720-20-25-1010	COVER PLATE	13386	\$37.50
6	720-20-25-1025	O-RING, COVER PLATE	400144	\$8.25
7	720-20-25-1020	NECK RING	13384	\$3.50
8	720-20-25-1027	SCREW – IMPELLER	13367-4	\$11.50
9	720-20-25-1018	IMPELLER TOP – 1ST STAGE	13381-1	\$61.25
10	720-20-25-1016	IMPELLER BOTTOM – 1ST STAGE	13380-1	\$41.60
11	720-20-25-1022	NECK RING BALANCE – 1ST STAGE	13558	\$3.50
12	720-20-25-1011	DIFFUSER – 1ST STAGE	13383	\$56.60
13	720-20-25-1012	DIFFUSER – 2ND STAGE	13382	\$56.60
14	720-20-25-1021	NECK RING – INNER STAGE	13476	\$3.50
15	720-20-25-1019	IMPELLER TOP – 2ND STAGE	13379-1	\$45.50
16	720-20-25-1017	IMPELLER BOTTOM – 2ND STAGE	13376-1	\$50.00
17	720-20-25-1023	NECK RING BALANCE – 2ND STAGE	13366	\$3.75
18	720-20-25-1029	MECHANICAL SEAL	48779	\$84.93
19	720-20-25-1024	O-RING, CASING	43063	\$10.25
20	720-20-25-1004	KIT – BOLT, WASHER, O-RING	31327-4	\$6.75
21	720-20-25-1009	CASING – REAR	13039-1SPR	\$100.75
22	720-20-25-1015	GASKET – DISCHARGE 3-WAY	13539	\$12.50
23	720-20-25-1013	OUTLET – 3-WAY, 1-1/2” NPT	13498SPR	\$61.25
24	720-20-25-1028	SCREW, OUTLET	9615-10-3	\$13.54
25	720-20-25-1007	BLANK CAP ASSY – 1-1/2” NPT	32169	\$6.25
26	N/A	GASKET, 1-1/2” CAP	13490	
27	720-20-25-1006	BLANK CAP ASSY. – 1” NPT	32170	\$4.75
28	N/A	GASKET, 1” CAP	13489	



PUMPS & PARTS

Darley 2BE18V with Mechanical Seal

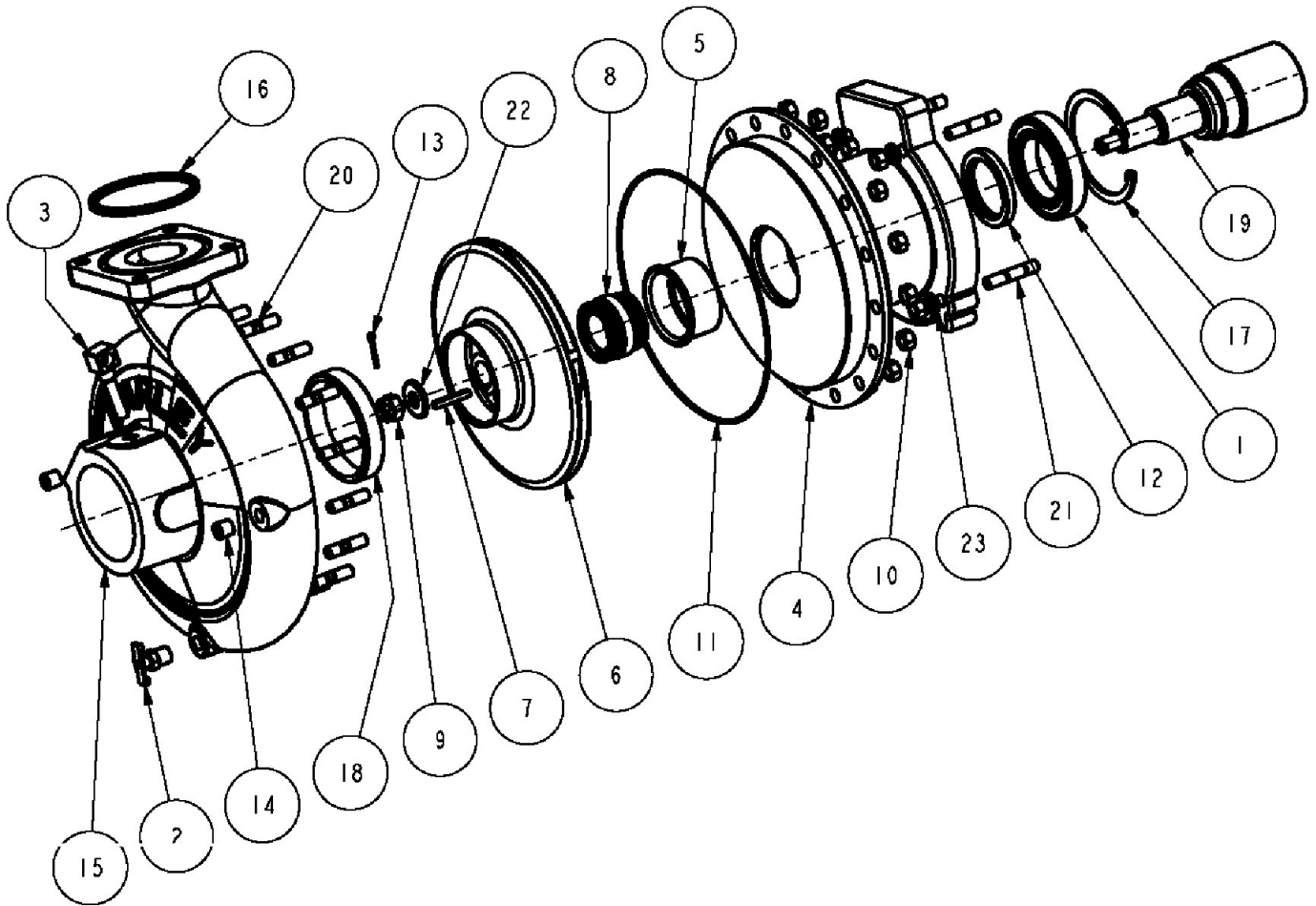

Ref	Description
1	Bearing-Ball, 111KSZZ
2	Draincock—1/4" NPTM, 9KC BR
3	Fitting—Primer Suction
4	Head—Inboard, 2BE
5	Housing—Mechanical Seal, 2BE
6	Impeller—2BE18, RH
7	Key—Sq., .19 x 1.38, SS
8	Mechanical Seal—1.25"
9	Nut—Castle, 1/2"-20, 303
10	Nut—Hex, 3/8"-16, SS
11	O-Ring—8.25 x 8.44 x .09
12	Oil Seal—1.937 ID x 2.629 OD

Ref	Description
13	Pin—Cotter, 3/32 x 1, SS
14	Plug—1/4" NPT, SS SH
15	Pump Casing—2BE
16	Quad Ring—3.25 x 3.62 x .19
17	Ring—Retainer, 5160-137
18	Seal Ring—B
19	Shaft—Impeller 2BE18BS
20	Stud—3/8"-16 x 1-1/2", 303
21	Stud—3/8"-16 x 2", 303
22	Washer—1/4" x 1-1/4" x .12
23	Washer—Lock, 3/8", SS
	Pump End; Complete—No Engine



PUMPS & PARTS

Darley 2BE18V with Packing

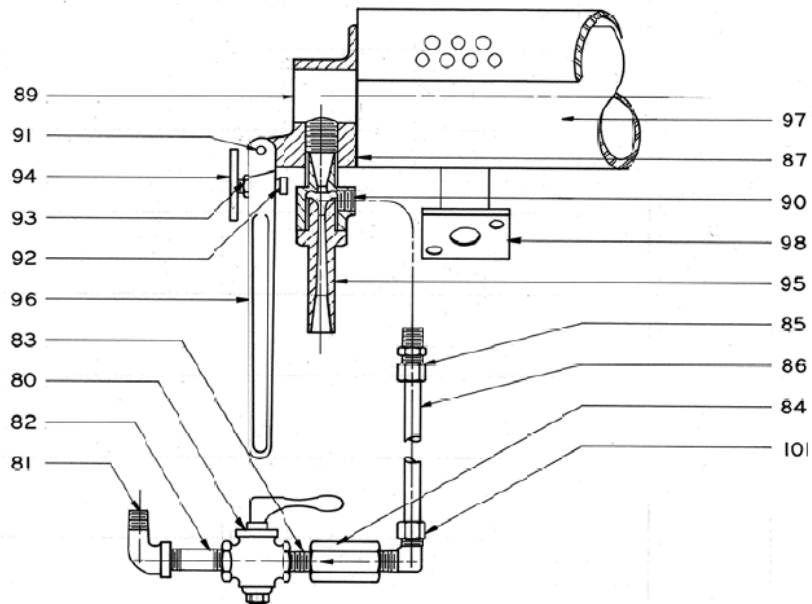
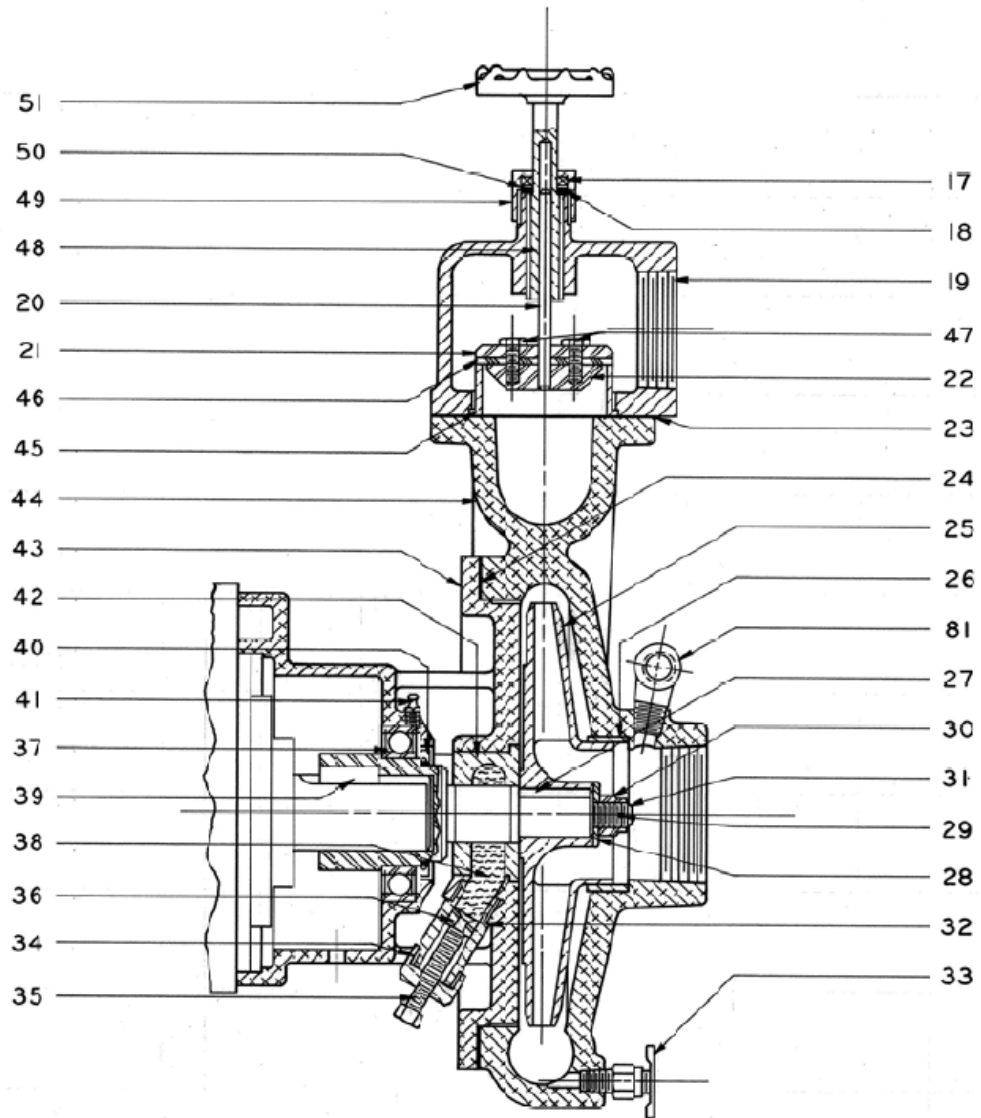

PUMPS & PARTS

Darley 2BE18V with Packing

Ref	Description
17	VALVE STEM PACKING
18	STUFFING BOX WASHER GASKET
19	DISCHARGE HEAD
20	CHECK VALVE STEM
21	CHECK VALVE PLATE
22	CHECK VALVE DIFFUSER
23	DISCHARGE HEAD GASKET
24	PUMP CASING GASKET
25	IMPELLER
26	SEAL RING
27	IMPELLER KEY
28	IMPELLER WASHER
29	COTTER KEY
30	IMPELLER NUT
31	IMPELLER SHAFT
32	PACKING CYLINDER
33	DRAIN COCK
34	GLAND NUT
35	PACKING SCREW
36	GLAND NUT
37	BEARING
38	PUMP PACKING
39	IMPELLER SHAFT KEY
40	OIL SEAL
41	GREASE ZERK
42	PACKING BOX
43	INBOARD HEAD

Ref	Description
44	PUMP CASING
45	CHECK VALVE SEAT
46	CHECK VALVE GASKET
47	HEX HEAD CAP SCREWS
48	VALVE STEM
49	GLAND NUT
50	STUFFING BOX WASHER
51	HAND WHEEL
80	1/4 TURN VALVE
81	PRIMER SUCTION FITTING
82	PIPE NIPPLE
83	CLOSE NIPPLE
84	CHECK VALVE
85	STRAIGHT COMPRESSION FITTING
86	COPPER TUBING
87	GASKET
89	EXHAUST VALVE BODY
90	PRIMER JET
91	SPRING PIN
92	DISC ADJUSTMENT SCREW
93	JAM NUT
94	EXHAUST VALVE DISC
95	PRIMER THROAT
96	EXHAUST VALVE LEVER
97	CROSSOVER MUFFLER
98	GASKET
101	90 COMPRESSION FITTING



PUMPS & PARTS

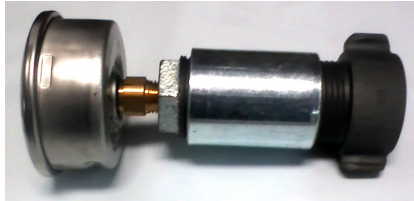
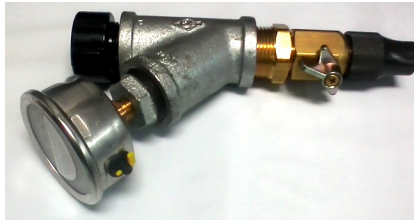

Pump Test Kit

Designed for testing of pumps up to 200 PSI. This kit contains all the equipment necessary to test both the suction and pressure sides of pumps.

Part # 999-00-10-1005 \$413.76

Hand Primer

Hand operated pump priming tools. Used to prime the pump before starting to prevent the pump from running dry.



Jabsco 33745 Hand Primer, 1.75"D x 22.5"
Part # 120-74-10-1001 \$294.02



Jabsco 33799 Hand Primer, 1.25"D x 12"
Part # 120-74-10-1008 \$86.36



Hose Blowout Fitting

Designed for use with air compressor to blow water out of hose and fire water system. Comes with 3/4" F-GHT fitting. Use adapters to fit other sizes. (Common sizes listed below)

Part # 999-00-10-1010 \$9.00

340-56-63-1034	1" F-NST X 3/4" M-GHT	\$19.09
340-56-64-1510	1-1/2" F-NST X 1" M-NST	\$20.14
340-56-63-1534	1-1/2" F-NST X 3/4" M-GHT	\$16.17



FOAM UNITS & ACCESSORIES

Foam Unit, Scotty 4171

The 4071 Foam Eductor/Mixer is a simple "A-the-P" unit to educt foam concentrate into hose lines. It is mounted between the discharge and suction side of a pump. For use on portable forestry pumps or fitted permanently to skid units, the 4071 is a simple and effective way to add a foam capability to equipment. The unit is adjustable, permitting various foam ratio percentages to be educted depending on the nozzles being used. Includes the eductor, pressure hose, pick-up hose and two connecting tees; a 1 1/2" and a 2" size with NPSH threads.



Part # 340-50-10-1000 \$439.80



Scotty 4171—Eductor Only

The unit is adjustable, permitting various foam ratio percentages to be educted depending on the nozzles being used. **DOES NOT INCLUDE** pressure hose, pick-up hose and two connecting tees.

Part # 340-50-10-1003 \$270.32

Foam Pail Adapter

Part # 340-50-10-1006 \$17.15



Foam Unit, Cascade Foam-Flo

The Foam-Flo™ meters wildland (class A) foam concentrate into hose lines in the desired percentages. The Foam-Flo™ can treat up to 100 GPM or as low as 5 GPM of water. Foam concentrate can be metered into the hose lines in various amounts, from .01% to 1%. All hoses and fittings included

Part # 340-50-30-1001 \$403.00

Foam, Class A, 5 gal

5 gallon pail of Class A foam. Specifically formulated to make water more effective. The unique combination of surfactants reduces water's surface tension, creates a superior foam blanket when mixed with air that surrounds fuels with a thick layer of water, creates a barrier between the fuel and the fire, allows fire fighters to see application areas, and knocks down fire faster than water alone. Tested and qualified by the USFS. The U.S. Forest Service tests for corrosion properties along with environmental, safety and health testing. These tests ensure that the product is safe for the personnel who use it and safe for the environment.

SEE NEXT PAGE FOR MORE INFORMATION



Part # 340-41-10-0881 \$107.59 (est. shipping charge \$16/pail)



FOAM UNITS & ACCESSORIES

The Stockroom provides foam to Fire Departments and Cooperating Non-Profit organizations to support our partners' wildland fire suppression and prescribed fire needs. **Orders are limited to 10 pails per year *** per organization.** If your wildland fire needs exceed that amount, contact your local ranger to pursue an exception. (*****per year is calculated from last foam order date**)

To better serve our customers, we have established several foam caches around the state. **Just complete the order form as you normally would and note in the "comments" section at which cache you would like to pick up.** We will forward the necessary paper work to the appropriate contact and you can contact them directly to arrange pick up.

FOAM CACHE CONTACTS		
POYNETTE N3344 STEBBINS RD	BROOKE HUSHAGEN	608-635-8121
WAUTOMA 427 E. TOWER DR	JARED LABBUS	920-604-5605
FRIENDSHIP - 532 N. MAIN ST	ALEX GRUBBS	715-490-0610
BLACK RIVER FALLS - 910 HWY 54 E	SCOTT LOVELAND	715-896-0535
BRULE - 6250 S. RANGER RD	ADAM STEGMANN	715-815-0658
SPOONER - 810 W. MAPLE ST	REBECCA STEIGERWALDT	715-416-0102
WAUSAUKEE - 1025 HWY C	KEVIN GILBERT	715-923-1310

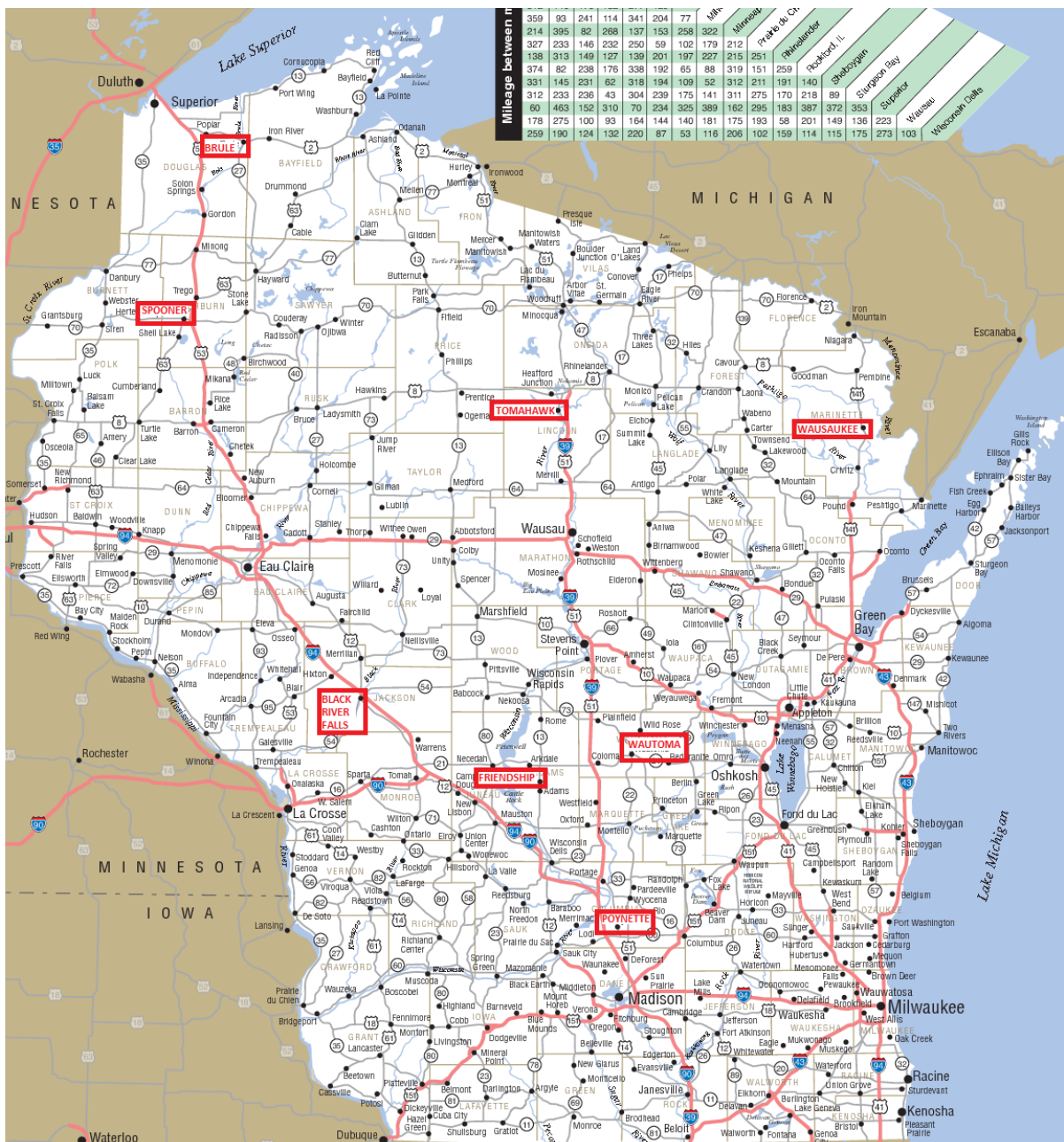

HOSE REELS & PARTS

Hose Reel Model EF4038-17-18RT

Low profile, electric. Inlet, outlet riser and rewind mechanism on the operator's right. Hose unwinds from the top of the reel. Reel holds 200' of 3/4" hose or 100' of 1" hose. Net wt. is 70#, ship wt. is 112#. Red in color.



Part # 340-32-63-2001 \$820.37

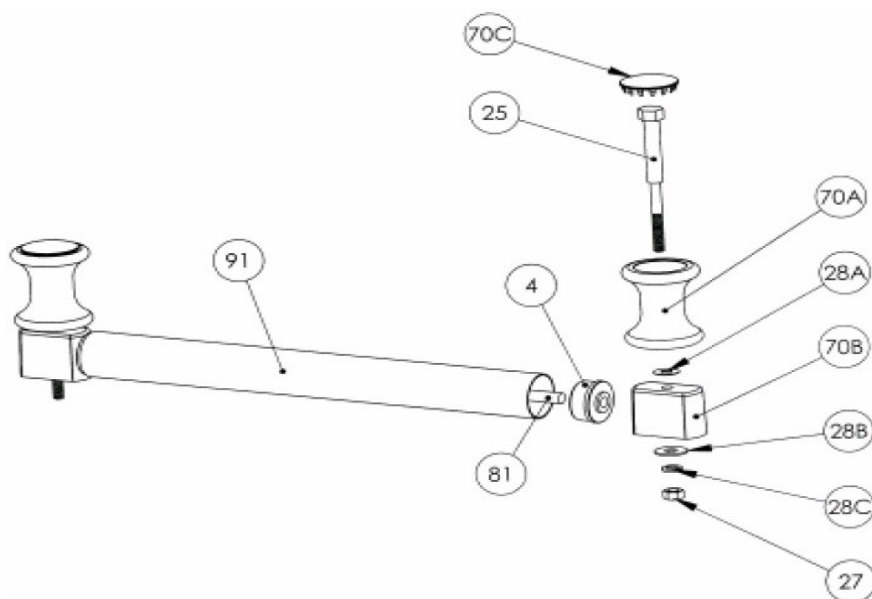

Ref	Part #	Description	Price	Ref	Part #	Description	Price
4	340-32-50-3032	Trunion Bearing FH-303-2	\$5.50	70C	340-32-50-3090	Cap-Black Plastic FH-309P	\$3.10
25	340-32-50-3070	Step Bolt FH-307	\$9.25	81	340-32-50-3040	Rod FH-304	\$18.25
70A	340-32-50-3010	Spool FH-301	\$28.95	91	340-32-50-3050	Roller; 24" FH-304	\$23.25
70B	340-32-50-3020	Block FH-302	\$16.95		340-32-50-0324	Complete Roller Assy FH-324	\$150.00

Hose Reel Remote—(Used for hose reel operation on many DNR vehicles)

Heavy-duty rubber housing, rubber boot cover on metal switch keeps out dust and rain, bright yellow strap wraps around wrist and keeps remote in hand and 15' cord provides operation of winch from inside of vehicle.

Part # 065-94-76-3447 \$44.65



Hose Reel Swivel

Swivel joint for hose reels. 1" -90 swivel elbow with female pipe thread on both ports. Includes a grease zerk

Part # 340-32-64-1010 \$75.10



WINCHES & COMPONENTS

Winch, Warn Zeon 10-S multi-mount

All the power and reliability of the Zeon 10S in a portable package. Max line pull of 10,000 lbs at 4.8 feet per minute. Includes 3/8 x 100 foot Spydura Synthetic Rope. Max draw is 409 Amps at 10,000lbs. Plugs into any standard 2" Class III receiver hitch and gives you the ability to move the winch from the front or back of your rig. This Kit includes winch, remote, carrier, 7.5' power lead with quick connect plug for front of vehicle and hawse fairlead. Requires 2" receiver for mounting.



Part # 065-94-76-7441 \$1,569.99



Winch, Replacement Cable **DISCONTINUED—LIMITED AVAILABILITY**

Constructed of aircraft wire rope. Galvanized to help resist corrosion. Includes swaged loop on one end and wire rope terminal on other end. 5/16 in. x 125 ft, 9000# capacity.

Part # 065-94-76-5987 \$177.00

Winch, Replacement Cable

WARN 102560 Spydura Nightline Reflective Synthetic Winch Cable Rope with Swivel Hook End: 3/8" Diameter x 80' Length, 6 Ton (12,000 lb) Capacity. Coated with durable, ultra-high-molecular-weight polyethylene with UV-stability
Dual-color weave with 3M light-activated reflective strand improves visibility
Winch line features red, heat resistant Nome sleeve that protects the first layer of rope from drum temperature and provides a visual end-of-line warning.



Part # 065-94-76-2560 \$295.25



Winch, Power Lead, 20ft

Warn Cable Kit, 20', 175 Amp. 20'6m Quick Connect power cable, for rear of vehicle. Includes power interrupt kit. The power interrupt kit allows you to connect aftermarket accessories to a battery lead and then disconnect power from a dash mounted switch. Recommended for extra protection.

Part # 065-94-76-2963 \$241.81



WINCHES & COMPONENTS

Winch, Wireless Remote

The WARN Wireless Control System lets you remotely control your WARN truck/SUV winch from up to 50 Foot away. The new system is plug-and-play: It simply plugs in where you'd normally attach your corded remote - no wiring, no hassle. Will work with any five-wire WARN truck/SUV winch. Weatherproof transmitter has two large buttons making it easy to operate, even while wearing gloves. Two-color LED provides clear operator feedback.

- Control Your Winch From Up To 50 Foot Away
- Fits All Warn Truck/SUV Winches With A 5-Wire Control Pack
- Sealed For Protection Against The Elements
- Activation Sequence Guards Against Accidental Power-Ups
- Kit Includes Wireless Transmitter, Receiver, Holster, Lanyard And Mounting Hardware
- Easy Plug-And-Play Installation
- Limited 1 Year Warranty



Part # 065-94-76-0287 \$176.20



Winch, Snatch Block for Wire Rope

20,000-pound pulling capacity, Comes with grease port and overload indicator, Designed for winches with up to 10,000 pound capacity with 3/8 inch **wire rope**, Helps to reduce heat buildup and amp draw, Can double the pulling power of any winch.

Part # 065-94-76-5640 \$92.39

Winch, Snatch Block for Synthetic Rope

24,000-pound pulling capacity, Comes with grease port and overload indicator, Designed for winches with up to 12,000 pound capacity with 3/8 inch **synthetic rope**, Helps to reduce heat buildup and amp draw, Can double the pulling power of any winch

Part # 065-94-76-9218 \$114.09



DECALS

DIESEL FUEL

DRINKING WATER

GASOLINE

Mixed Gas

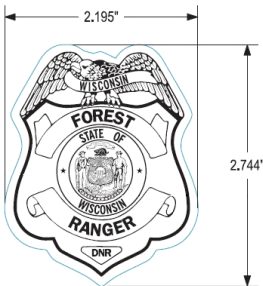

FOR DNR USE ONLY

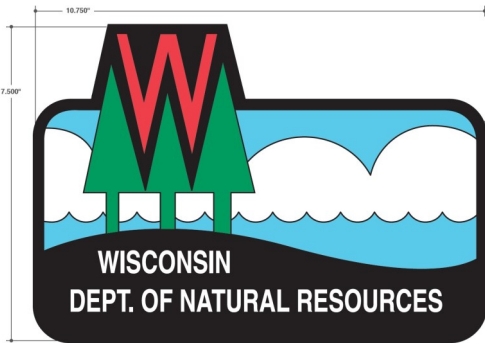
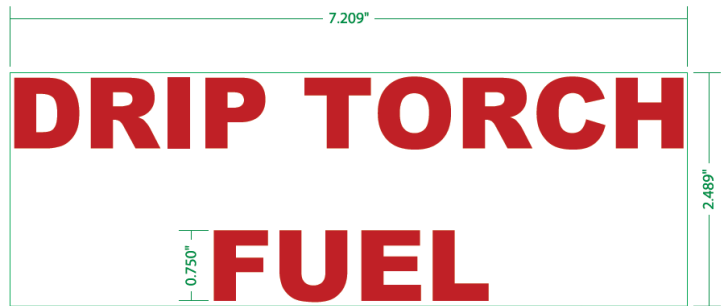

FOR DNR USE ONLY



FOR DNR USE ONLY

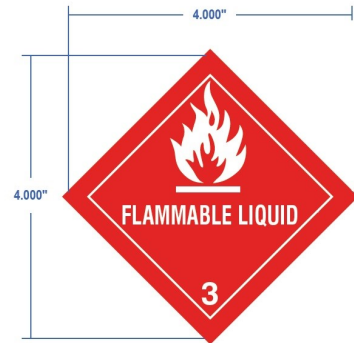

Part #	Description	Price
255-26-10-1002	Decal; "DIESEL FUEL"; 2" x 7"	\$0.35
255-26-10-1009	Decal; "GASOLINE"; 2" x 7"	\$0.35
255-26-10-1003	Decal; "DRINKING WATER"; 3" x 5"	\$0.35
255-26-10-1011	Decal; "MIXED GAS"; 2" x 4"	\$0.35
255-26-10-1022	Decal; Forest Ranger Badge; 2-1/4" x 2-3/4"	\$1.24
255-26-10-1031	Decal; "Drip Torch Fuel"; 2-1/2" x 7-1/4"	\$0.47
255-26-10-1018	Decal; DNR Logo; 7-1/2" x 10-3/4"	\$5.00
255-26-10-1030	Decal; DNR Logo; Small; 2-1/2" x 3-1/2"	\$1.40
255-26-10-1032	Decal; "Flammable Liquid"; 4" x 4"	\$0.70



SIGNS & PARTS

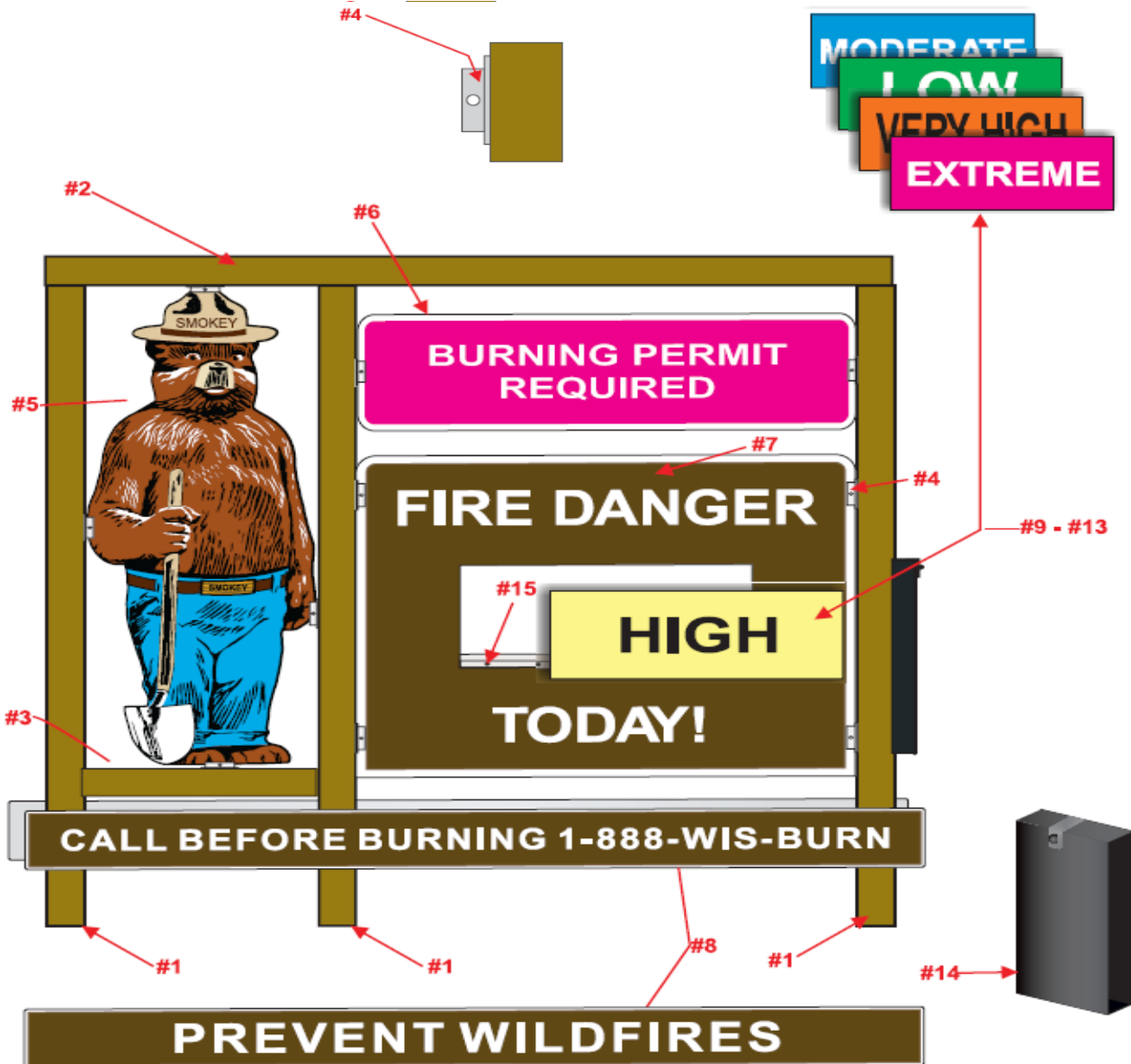

Ref	Part #	Description	Price	Ref	Part #	Description	Price
	999-90-00-8000	Smokey Sign, Complete	\$1,558.55	8	999-90-00-8008	Prevent Wildfires/1-888-WIS-BURN	\$123.60
1	N/A	Post 4" x 4" x 12ft	N/A	9	999-90-00-8009	Adjective, "Extreme"	\$55.38
2	N/A	Post, 4" x 4" x 94"	N/A	10	999-90-00-8010	Adjective, "Very High"	\$55.38
3	N/A	Post, 4" x 4" x 33-3/8"	N/A	11	999-90-00-8011	Adjective, "High"	\$55.38
4	999-90-00-8004	Universal Bracket, 12"	\$13.07	12	999-90-00-8012	Adjective, "Moderate"	\$55.38
5	999-90-00-8005	Smokey Bear	\$436.97	13	999-90-00-8013	Adjective, "Low"	\$55.38
	999-90-00-8001	Small Wing Bracket	\$9.20	14	999-90-00-8014	Adjective Storage Box	\$258.72
6	999-90-00-8006	Burning Permits Required	\$89.15	15	999-90-22-8015	Offset Bracket	\$35.50
7	999-90-00-8007	Fire Danger Today	\$286.49		999-90-00-8016	Hardware Kit	\$120.25



SIGNS & PARTS

Sign, Emergency Fire Warden—**FOR DNR PURCHASE ONLY**
22" x 15.5" Aluminum two sided wit Hi Intensity Prismatic sheeting

Part # 999-90-00-8018 \$35.00



Sign Bracket, Universal 12"

Aluminum sign bracket for mounting Emergency Fire Warden Sign, also a component of the Smokey Bear Fire Danger Sign.

Part # 999-90-00-8004 \$9.20

Sign, DNR Logo, Aluminum—**FOR DNR PURCHASE ONLY**
17" x 22", single sided. Aluminum, die-cut sign is reflective and features pre-drilled mounting holes.

Part # 801-76-11-1001 \$23.01



Sign, DNR Logo, Magnetic—**FOR DNR PURCHASE ONLY**
Approximately 10" wide x 12" long, reflective, magnetic backed sign.

Part # 801-82-10-1004 \$11.20



SIGNS & PARTS

SIGN; PESTICIDE WARNING W/WIRE STAKE—**FOR DNR PURCHASE ONLY**

This wind- and weather-resistant Pesticide Warning Sign features the correct legend and legend size that makes it EPA-approved. Available with vertical fluting, so it will slide onto the top of a step stake (included).

Part # 345-40-58-1895 \$10.24



Sign; Feather Flag; Windy?

Feather flag and stand, single sided.

Part # 350-10-10-1001 \$272.79



BANNER; VINYL; 4FT X 16FT; FIRE ENGINE

4FT X 16FT, single sided, vinyl banner. Grommets every 18 inches and rope sewn in hem.

Part # 350-10-11-1001 \$162.05



BANNER; VINYL; 4FT X 16FT; WILDFIRES

4FT X 16FT, single sided, vinyl banner. Grommets every 18 inches and rope sewn in hem.

Part # 350-10-11-1002 \$162.05



SIGNS & PARTS

PREVENTION SIGNS—FOR DNR PURCHASE ONLY

Aluminum signs with fire prevention messages. 12" x 18".

ATV WILDFIRE RISK
Part # 000-ATV



BURNING PERMITS REQUIRED
Part # 000-PERMITS REQ

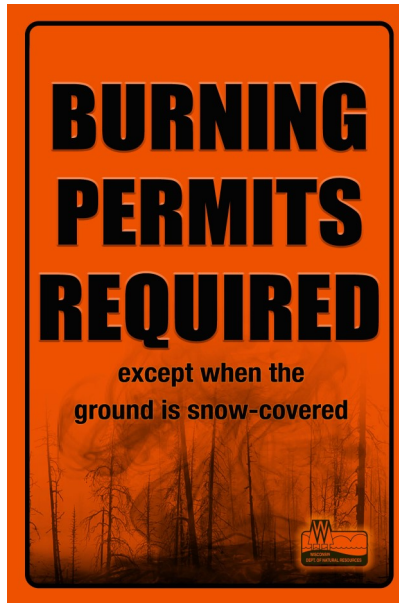

CHECK BEFORE YOU BURN!
Part # 000-CHECK



COOL CAMPFIRES
Part # 000-CAMPFIRES



WINDY TODAY?
Part # 000-WINDY



PREVENT WILDFIRES
Part # 000-SMOKEY



SIGNS & PARTS

PREVENTION SIGNS—FOR DNR PURCHASE ONLY

These weather-resistant plastic signs have vertical fluting, so they will slide onto the top of a step stake (included). Measures 24"W x 18"H.

YARD SIGN; PERMITS SUSPENDED W/WIRE STAKE

Part # 345-40-58-8000



YARD SIGN; ELEVATED FIRE RISK W/WIRE STAKE

Part # 345-40-58-8100



SIGN; BURNING PERMITS SUSPENDED

This aluminum sign is for use with the Smokey Bear fire danger signs. It measures 16"H x 48"W and is designed to cover the "Burning Permit Required" sign when appropriate. Single sided.

Part # 999-90-00-8020

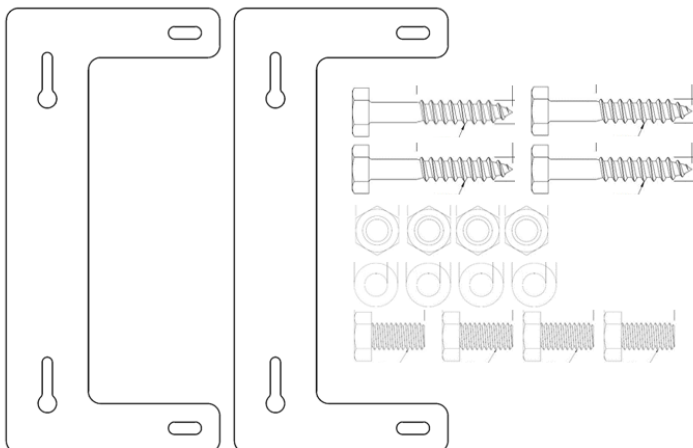

HARDWARE KIT; BURNING PERMITS SUSPENDED

Includes all the necessary lag screws, bolts, washers, nuts and brackets to mount the sign to an existing Smokey Bear prevention sign.

Part # 999-90-00-8026 \$11.84



PREVENTION SIGNS—**FOR DNR PURCHASE ONLY**

SMOKEY FIRE DAGER SIGN; HIBERNATING

This aluminum sign is for use with the Smokey Bear fire danger signs. It is the same size as the adjective levels and is for use during off-season.

Part #000-OFFSEASON



SIGN; HAZARDOUS FOREST FIRE AREA

This aluminum sign measures 18"H x 24"W.

Part # 000-HAZAREA



FORESTRY EQUIPMENT

Clinometer

Clinometers can be used to measure heights of trees, towers, buildings, etc.; to measure slopes for grading or preliminary surveying; and to measure vertical angles for cellular and satellite installations and more. Features a solid aluminum housing with jeweled bearing assembly. Damped scale for smooth, accurate readings. Parallax-free lens. 1/4" x 20 threaded tripod socket. Includes lanyard and black nylon case. $\pm 150'$, $\pm 200'$ @ 66' baseline. Percent/degree conversions on back.

Part # 578-38-11-1001

\$126.11

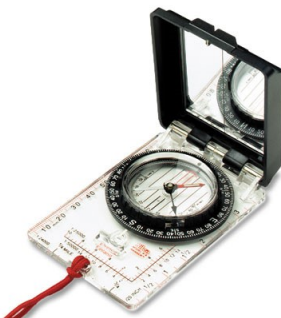

Compass, Ranger Type

Rotating compass dial with graduations every 2°. Swedish steel needle pivots on a liquid damped, sapphire jeweled bearing. Built-in magnetic declination adjustment screw. Mirror-sighting with luminous points. Needle orienting arrow and lines. Map magnifier. Clear protractor baseplate has inch scale edge (graduated in 20ths), millimeter scale edge and Romer Scales of 1:24,000, 1:25,000, and 1:50,000. Clinometer reads to $\pm 90^\circ$. 2-1/4" x 4" closed. Lanyard and instructions included.

Part # 578-38-11-1002

\$63.00

Tape, Diameter 10'

38" Diameter in inches and 10ths one side, 120" Linear in inches and 16ths (first 12" in 32nds) other side. 1/4" x 10' Yellow line steel tape has black markings. ABS case. Spring rewind. Blade lock. Dimensions: 2-1/8" x 1-7/8".

Part # 578-38-10-1003

\$7.81



Tape, Loggers 75'

Measures in feet, inches, 8ths on one side and 120" diameter inches, 10ths, other side. Designed for use in the most rugged conditions! Yellow enamel line, black graduations, black and red numbers, heavy-duty case, hardened steel gears and fast automatic rewind. All tapes sold without nail (order separately).

Part # 578-38-10-1005

\$72.49

Horse Shoe Nail

Accessory for Loggers Tape.

Part # 578-38-21-1007

\$0.85



FORESTRY EQUIPMENT

Pocket Steroscope

Precision ground meniscus lenses. Adjustable interpupillary range 50 mm to 70 mm. Field of view 125 mm x 125 mm. All metal cast alloy frame with fold-away wire frame legs. Supplied with vinyl case.

Part # 578-38-11-1004 \$25.85

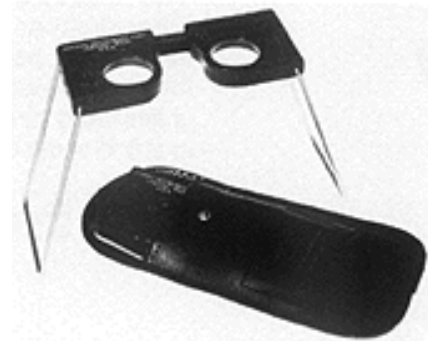

Increment Borer, 10" - 3 Thread

Use to extract cores of wood from trees or freshly treated poles, piling, lumber, or timbers to determine growth rate, age, tree soundness, and chemical penetration. Teflon® coating protects bit against rust and resin build-up and reduces friction. A 3-thread borer has three threads, each originating 120° apart. The higher thread pitch of the 3-thread borer will penetrate deeper per revolution than a 2-thread. A 3-thread will also produce less friction because more steel is in contact with the wood.

Part # 578-38-11-1003 \$204.21

Tally Meter, Hand

Count from 0 to 9,999. Fit comfortably in hand. Finger ring attached. Figures reset to zero by turning one knob. Shiny, plated metal finish. Meet U.S. Government Standards.

Part # 578-38-12-1001 \$13.51



Tatum, Clipboard

Clipboard is Lightweight and Strong—Stands Up to Daily Use

The dual-hinge on this Aluminum Clipboard allows top plate to be folded completely to back for easy handling. When the weather changes or you are finished writing the cover closes easily to protect your work. Clip will hold 9/16" thick pad of forms.

Part # 578-38-21-1006 \$32.76



FORESTRY EQUIPMENT

Paint Gun, Idico

Can adapter is permanently attached to the powder-coated all-metal gun housing. Self-storing, no drip brass nozzle cap, fine mesh screen strainer on intake tube.

Part # 578-38-16-1001 \$50.00



[PARTS LIST ON PAGE 63](#)



Paint Gun, Nel-spot

Attaches directly to a quart can without the need for an adapter. Made of lightweight but extremely strong material that keeps your hand warmer in the winter than metal models. Comes with reversible, self-cleaning 0.021" nickel-finished nozzle.

Part # 578-38-16-1002 \$223.50

[PARTS LIST ON PAGE 64](#)

Paint Gun, Treccoder

Works with ink or paint. One squeeze of the comfortable, four-finger trigger dispenses up to 1-1/2 times more product than other guns on the market. Shoots ink or paint 8' to 10'. Reversible, self-cleaning nozzle. Attaches to quart-sized cans of tree marking ink or paint (not recommended for use with water-based paints).

Part # 578-38-16-1003 \$179.25



[PARTS LIST ON PAGE 65](#)



FORESTRY EQUIPMENT

IDICO DUZ-ALL PAINT GUN PARTS

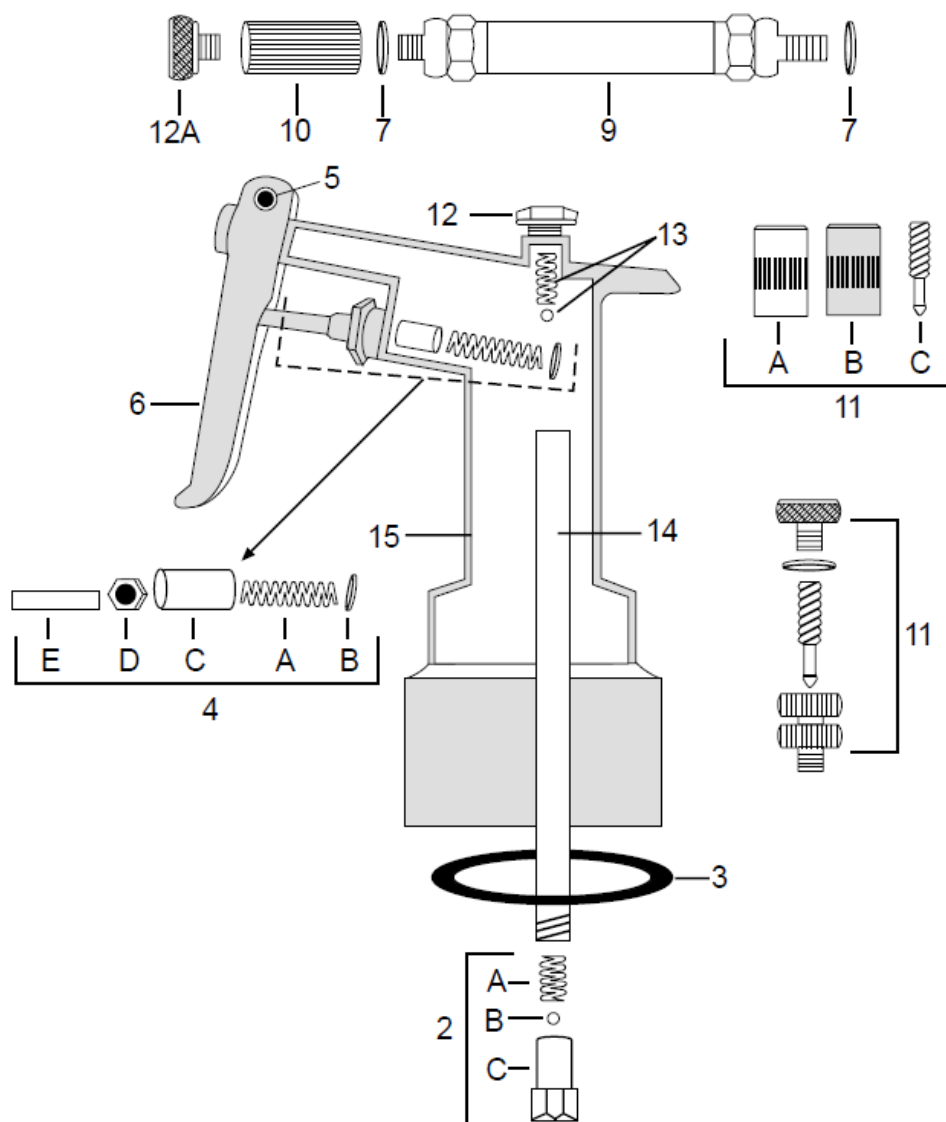

Ref	Part #	Description	Price
2	578-38-20-5810	INTAKE HOUSING ASSY	\$7.50
3	578-38-20-5815	CONTAINER GASKET	\$1.60
4	578-38-20-5816	VALVE ASSY	\$10.95
4A	578-38-20-5817	CYLINDER SPRING	\$1.50
4B	578-38-20-5818	CYLINDER GASKET	\$0.80
4C	578-38-20-5819	PISTON	\$5.95
4D	578-38-20-5820	VALVE LOCKNUT	\$2.50
4E	578-38-20-5821	VALVE STEM	\$1.20
5	578-38-20-5822	TRIGGER PIN	\$1.09

Ref	Part #	Description	Price
6	578-38-20-5823	TRIGGER	\$4.09
7	578-38-20-5824	WASHER	\$0.30
9	578-38-20-5826	STRAIGHT EXTENSION	\$5.95
10	578-38-20-5827	PIN STREAM NOZZLE	\$2.50
11	578-38-20-5869	FOG NOZZLE	\$7.73
12	578-38-20-5828	NOZZLE CAP HOLDER	\$3.20
12A	578-38-20-5874	NOZZLE CAP	\$1.82
13	578-38-20-5829	TOP BALL CHECK	\$4.95
14	578-38-20-5830	INTAKE TUBE	\$3.50



FORESTRY EQUIPMENT

NELSPOT DURABUILT PAINTGUN PARTS

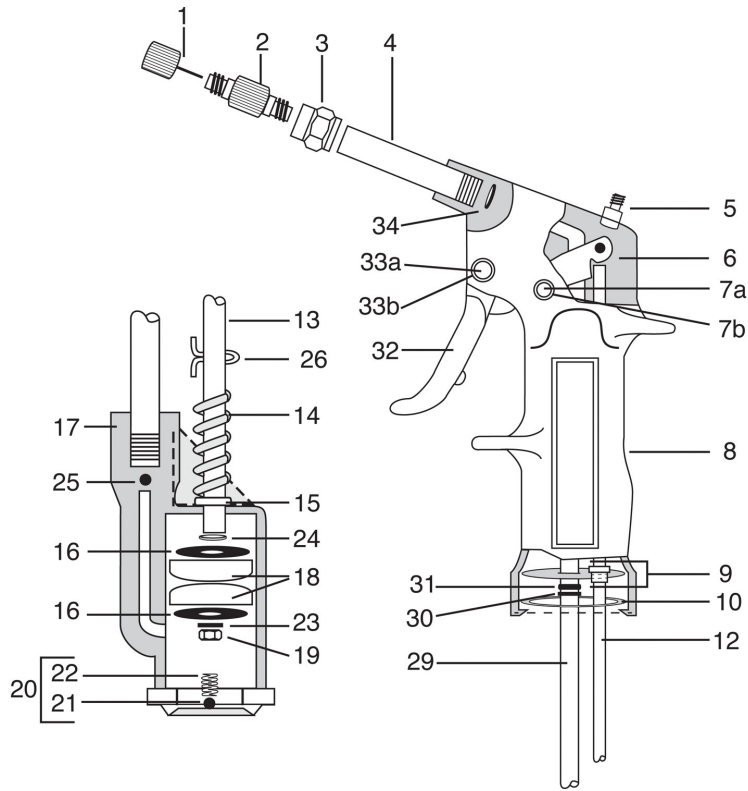

Ref	Part #	Description	Price
1	578-38-19-5834	NOZZLE CAP	\$5.46
2	578-38-19-5835	NOZZLE—REVERSIBLE	\$4.41
3	578-38-19-5836	RETAINING SLEEVE	\$6.97
4	578-38-19-5837	EXTENSION TUBE; 3"	\$6.97
5	578-38-19-5838	NOZZLE CAP HOLDER	\$18.76
6	578-38-19-5839	TRIGGER LINK	\$9.51
7A	578-38-19-5879	TRIGGER LINK PIN	\$3.69
7B	578-38-19-5880	RETAINING RING	\$1.76
8	N/A	HANDLE	
9	578-38-19-5842	SPACER DISC ASSY	\$5.36
10	578-38-19-5860	CONTIANER GASKET	\$1.76
12	578-38-19-5906	UPPER PISTON ROD	\$9.51
13	578-38-19-5846	LOWER PISTON ROD	\$8.04
14	578-38-19-5847	SPRING	\$1.71
15	578-38-19-5848	PISTON ROD WASHER	\$1.76
16	578-38-19-5849	WASHER	\$1.76
17	578-38-19-5850	CYLINDER	\$27.86

Ref	Part #	Description	Price
18	578-38-19-5851	CUP LEATHER	\$2.93
19	578-38-19-5852	HEX NUT	\$1.76
20	578-38-19-5853	INTAKE VALVE ASSY	\$13.84
21	578-38-19-5854	INTAKE VALVE BALL	\$1.76
22	578-38-19-5855	INTAKE VALVE SPRING	\$1.76
23	578-38-19-5730	LOCK WASHER	\$1.76
24	578-38-19-5857	WASHER	\$1.76
25	578-38-19-5790	STEEL BALL	\$1.76
26	578-38-19-5859	COTTER PIN	\$1.76
29	578-38-19-5862	FLUID TUBE	\$13.32
30	578-38-19-5863	RETAINER	\$1.76
31	578-38-19-5864	O-RING	\$1.76
32	578-38-19-5865	TRIGGER	\$30.98
33A	578-38-19-5881	TRIGGER PIN	\$3.92
33B	578-38-19-5882	SNAP RING	\$1.76
34	578-38-19-5867	GASKET	\$6.86



FORESTRY EQUIPMENT

TRECODER PAINT GUN PARTS

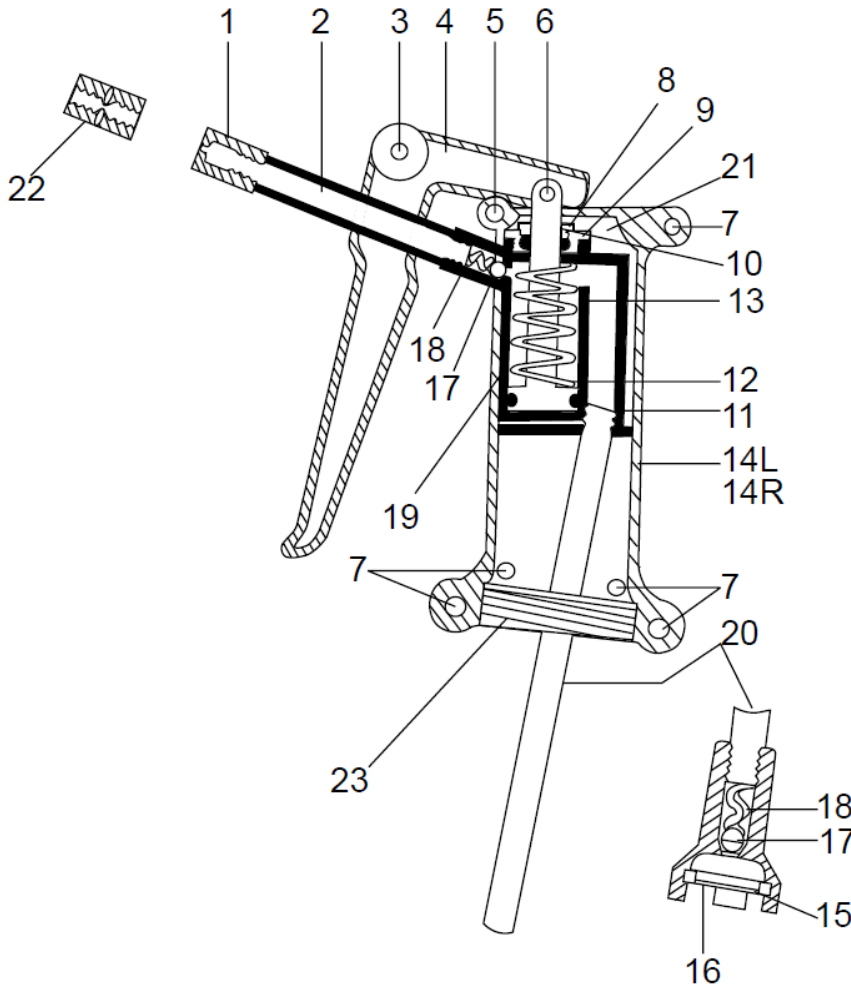

Repair Kit; Treccoder Paint Gun

Includes:

- #5 Handle Bolt; 7/8
- #6 Piston Rod Bolt
- #7 Handle Bolt; 5/8
- #10 O-Ring; 5/16
- #11 O-Ring; 3/4
- #16 Screen
- #17 Ball Valve
- #18 Ball Valve Spring
- #19 Piston Spring
- #21 Cylinder Cap Gasket

Part # 578-38-18-5584 \$29.25

Ref	Part #	Description	Price
1	578-38-18-5587	NOZZLE	\$5.41
2	578-38-18-5588	DISCHARGE TUBE	\$7.00
3	578-38-18-5589	TRIGGER PIVOT BOLT	\$1.04
4	578-38-18-5592	TRIGGER	\$8.54
5	578-38-18-5593	HANDLE BOLT; 7/8	\$1.04
6	578-38-18-5594	PISTON ROD BOLT	\$1.04
7	578-38-18-5595	HANDLE BOLT; 5/8	\$0.99
8	578-38-18-5596	PISTON ROD CAP	\$6.14
9	578-38-18-5597	CYLINDER CAP	\$8.41
10	578-38-18-5598	O-RING; 5/16	\$3.18
11	578-38-18-5599	O-RING; 3/4	\$3.18
12	578-38-18-5611	PISTON	\$14.46

Ref	Part #	Description	Price
13	578-38-18-5612	CYLINDER	\$23.21
14L	578-38-18-5613	HANDLE—LEFT	\$10.12
14R	578-38-18-5614	HANDLE—RIGHT	\$10.12
15	578-38-18-5615	FOOT VALVE	\$11.75
16	578-38-18-5616	SCREEN	\$1.43
17	578-38-18-5617	BALL VALVE	\$1.15
18	578-38-18-5618	BALL VALVE SPRING	\$3.02
19	578-38-18-5619	PISTON SPRING	\$4.82
20	578-38-18-5621	SUCTION TUBE	\$9.95
21	578-38-18-5622	CYLINDER CAP GASKET	\$2.08
22	578-38-18-5586	REVERSIBLE NOZZLE	\$8.25
23	578-38-18-5623	CONTAINER GASKET	\$4.75



FORESTRY EQUIPMENT

Cruising Vest

Designed to comply with ANSI/ISEA 107-2004 Class 2 Standards for high-visibility safety apparel. These vests feature: a compass pocket, a pencil pocket, a notebook pocket, two pockets at the waist (one with a flagging dispensing grommet and both with Velcro® closures), two inside pockets at the waist and one large pack pocket on the back which stretches across the full width of the vest. Plus, they have a handy mic tab. 100% polyester.



Small	578-38-15-1000	\$49.95
Medium	578-38-15-2000	\$49.95
Large	578-38-15-3000	\$49.95
X-Large	578-38-15-4000	\$49.95
2X-Large	578-38-15-5000	\$56.75



Cruising Stick

10-factor for basal area measurement, measures log height and diameter only (doesn't measure board footage). Use to determine number of logs in a tree, diameter, and to scale logs. Hard maple construction with a stainless steel ferrule on one end. Laser engraved graduations.

Part # 578-38-10-1001 \$25.00

Flagging Tape—

Vinyl flagging, 2 mil thick x 1-1/2" x 150feet long.



PART #	DESCRIPTION	PRICE	PART #	DESCRIPTION	PRICE
832-48-10-1001	BLUE	\$1.75	832-48-11-1004	RED GLO	\$1.50
832-48-10-1002	GREEN	\$1.75	832-48-11-1005	YELLOW GLO	\$1.50
832-48-10-1003	ORANGE	\$1.75	832-48-11-1006	PINK GLO	\$1.50
832-48-10-1004	RED	\$1.75	832-48-12-1005	YELLOW W/ BLACK STRIPE	\$3.25
832-48-10-1005	YELLOW	\$1.75	832-48-12-1006	PINK GLO W/ BLACK STRIPE	\$3.25
832-48-10-1006	WHITE	\$1.50	832-48-12-1007	WHITE W/ BLUE STRIPE	\$3.25
832-48-10-1007	BLACK	\$1.50	832-48-12-1008	ORANGE GLO W/ BLACK STRIPE	\$3.25
832-48-11-1001	BLUE GLO	\$1.50	832-48-13-1007	WHITE W/ BLUE POLKA DOT	\$2.25
832-48-11-1002	GREEN GLO	\$1.50	832-48-14-1003	ORANGE GLO; "KILLER TREE"	\$3.50
832-48-11-1003	ORANGE GLO	\$1.50	832-48-14-1006	PINK GLO; "ESCAPE ROUTE"	\$3.50



FORESTRY EQUIPMENT

Forestry Wedge, 12"

Hard plastic wedge aids in forestry work, such as tree felling and bucking.

Part # 578-38-21-1010 \$6.14



Cruz-All

Measure the basal area forest stands using any of these English BAF's: 5, 10, 20 or 40. Consists of an aluminum die-cut gauge and a 25" bead chain. To use, hold the button at the end of the chain in your teeth and extend the Cruz-All away from your eye until chain is taut. Looking through the Cruz-All, "count" all trees appearing wider at breast height than the opening for the basal area factor you're using.

Part # 578-38-10-1002 \$13.25

Photo Holder

Transparent on both sides. Flexible at all temperatures, these vinyl cases have an easy open/close plastic zipper. Available in 9-1/2" x 9-1/2" or 10-1/2" x 10-1/2".

9-1/2" x 9-1/2" #578-38-21-1004 \$2.09

10-1/2" x 10-1/2" #578-38-21-1005 \$3.05

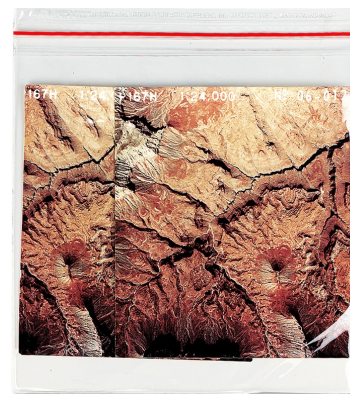

VALVES & STRAINERS

Ball Valve, Akron

Self-locking heavy-duty valve with a stainless steel ball designed for the harsh realities of today's fire service when water contaminants challenge a valve's sealing capabilities.

Size	Part #	Price
1"	670-70-45-0100	\$120.00
1-1/2"	670-70-45-0150	\$162.00
2-1/2"	670-70-45-0250	\$332.23



Repair Kit, Akron

Field service kit for Generation II Heavy Duty Swing-Out Valve. This service kit includes seats, o-rings and a Generation II stainless steel ball with Hydromax.

Size	Part #	Price
1"	670-77-11-1001	\$28.00
1-1/2"	670-77-11-1501	\$67.00
2-1/2"	670-77-11-2501	\$119.14

Ball Valve, 2-PC Brass

Bronze body two piece body, full port, 600 psi non-shock cold working pressure. Nibco T-585-70 or equivalent

Size	Part #	Price
1/4"	670-70-42-0014	\$21.84
3/8"	670-70-42-0038	\$22.53
1/2"	670-70-42-0012	\$30.95
3/4"	670-70-42-0034	\$29.10
1"	670-70-42-0100	\$45.03
1-1/2"	670-70-42-0150	\$123.26



Ball Valve, 3-PC Brass

Bronze body three piece body, full port, 600 psi non-shock cold working pressure. Nibco T-595-Y or equivalent



Size	Part #	Price
3/4"	670-70-43-0034	\$115.87
1"	670-70-43-0100	\$155.36
1-1/2"	670-70-43-0150	\$293.22



VALVES & STRAINERS

Ball Valve, Male x Female

Self-locking heavy-duty valve with a stainless steel ball designed for the harsh realities of today's fire service when water contaminants challenge a valve's sealing capabilities.

1/4" # 670-70-40-1014 \$9.20
 3/4" #670-70-40-3434 \$15.71



Check Valve, Bronze

Bronze ring check valve, inline lift type, spring actuated, 250 psi non-shock cold working pressure.

Size	Part #	Price
3/8"	670-70-47-0300	\$37.30
1/2"	670-70-47-0400	\$39.74
1"	670-70-47-0800	\$65.22
1-1/2"	670-70-47-1200	\$94.90

Check Valve

A spring-close design prevents slamming when valves close to stop backward flow. Body is brass. At least 1 psi is required to open valves. Install in any direction. Connections are NPT. Male or Female inlet with opposite outlet. 500 PSI max pressure, Temp. Range: -20° to +180° F

Size	Part #	Price
1/4 MxF	670-70-48-0200	\$18.25
1/4 FxM	670-70-49-0200	\$18.25
3/8 MxF	670-70-48-0300	\$22.40
3/8 FxM	670-70-49-0300	\$22.40

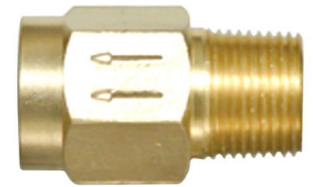

Arrows indicate flow direction



Butterfly Valve, Aluminum

An aluminum body provides strength and corrosion resistance at a lighter weight. Valves have alignment guides and fit ANSI Class 125 and 150 flanges with the same pipe size. Disc is Type 316 stainless steel.

Part # 670-71-03-0600 \$225.14



VALVES & STRAINERS

Ball Valve, Plastic

Precision Molded in Polypropylene - reinforced with fiberglass for additional strength, 304 Stainless Steel Bolts and nuts, Self-aligning ball moves freely against the PTFE seats for smooth operation. The valve opens or closes with very little pressure on the handle. Ball is diamond turned, after molding, to make it spherically perfect, which provides precise contact between ball and seats. PTFE self-lubricating stem bushings and seats cannot stick or bind.



Size	Part #	Price
3/4"	670-75-16-0075	\$30.90
1"	670-75-16-0100	\$34.00
1-1/2"	670-75-16-0150	\$43.40



Check Valve, Poly

A glass-filled polypropylene body provides good strength in a lightweight valve. At least 0.33 psi is required to open. Install in any direction. Color is black. Connections are 1/2" NPT female, 2-1/2" long.

Part # 670-70-46-0400 \$16.35

T-Strainer, Poly

Clean out your strainer less often—a T-shape body provides greater dirt-holding capacity than Y-strainers. Strainers have a black glass-filled polypropylene head. Screen is Type 304 stainless steel and seal is EPDM. Connections are NPT female.

	1/2"	Price	1"	Price
Strainer, Complete	765-77-71-0012	\$25.07	765-77-71-1016	\$33.06
Bowl	765-77-71-0501	\$12.12	765-77-71-2016	\$10.77
Gasket, Bowl	765-77-71-0020	\$2.69	765-77-71-1003	\$0.05
Screen			765-77-71-0101	\$11.49



Y-Strainer, Poly

Body is black fiberglass-reinforced polypropylene, screen is Type 316 stainless steel, and seal is EPDM. Connections are 1" NPT female. 5-5/8" X 6".

Part # 765-77-72-1001 \$27.11



TRUCK PARTS—ELECTRICAL

Flasher, Code 3 Model 711

Multiple mode flasher uses an electronic timing circuit to control two specially designed flasher relays. It can be used as a headlight flasher, non daytime running lights hot side switching flasher or as a light bar flasher with steady burn override capability.

Part # 055-83-35-0711 \$45.00

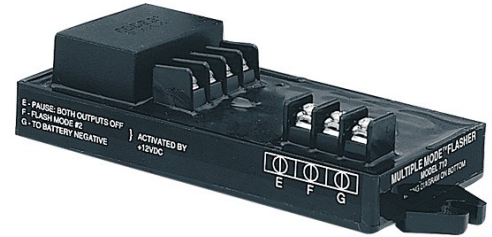

Flasher, Whelen UHF2150A

Two outlet, 162 watts per outlet headlight/grille light flasher in a compact molded polycarbonate housing with external mounting flanges. For use on positive or negative headlight switching. Solid-state controlled relay output. Four flash patterns. Dimensions: 3" (76mm) H x 1-1/2" (38mm) D x 4-3/16" (108mm) W.

Part # 055-83-35-2150 \$58.00

Light Assemble, LED

LED worklight used on rear of some Type 4 Engines.

Part # 055-46-31-2060 \$40.00



Light, M4R

The unique lens shape and patented Linear-LED designed reflector assembly are completely illuminated for unmatched high intensity warning and low current consumption! 129 Scan-Lock flash patterns with Phase 1 and Phase 2 for alternating/simultaneous flashing and steady-burn.

Part # 055-57-21-2040 \$113.38

Light, LED Scene

Surface mount LED scenelight features inner optics that directs light downward without angle brackets. Completely illuminated with no dark spots. Certified to meet AMD standard 024 for perimeter illumination. Lighthead draws only 6 amps and produces 6500 useable lumens.

Part # 055-46-31-0600 \$167.85



TRUCK PARTS—ELECTRICAL

Light, LED S/T/T

Sealed, flush mount, red LED stop, turn and tail light. 10 super diodes for bright, dependable performance. Meets DOT FMVSS 108 requirements in any 360 degree position. Features sonically sealed, waterproof lens and housing in a single unit. All-weather, molded plastic housing and durable lens protect against corrosion.



Clear Lens	Part # 055-46-21-2502	\$17.80	Pigtail #055-48-50-6716	\$1.50
Red Lens	Part # 055-46-21-6050	\$16.70	Pigtail #055-48-50-4993	\$2.50



Light, LED Oval Warning—Red

Collimating lens concentrates light into one solid beam of light. Fits standard 6 inch oval body cutouts. Reliable & powerful Gen 2 LED output. Includes Rubber Grommet, AMP Sure Seal Connector & Mating Harness. Clear lens light in Red. Self-contained with 8 flash patterns. 3 Year Warranty. **607101-04**

Part # 055-57-21-1014 \$67.82

Light, LED Oval Backup

Light, LED, Interior, Dome Style, Oval, Clear Lens, 6.500 in. Length, 2.250 in. Width, 1.375 in. Height.



Part # 055-46-11-1981 \$58.18



Light, LED License

Low-profile shape, Vibration-resistant lamp, Slotted mounting holes fit most lamp mounting screw patterns and withstand excessive torque without cracking. Not polarity sensitive, Encapsulant potting for total circuit-board protection.

Part #055-46-31-0341 \$40.80

Light, LED Clearance/Marker

LED clearance or marker light. 2-1/2" round.

Light #055-48-20-1002	\$8.25
Pigtail #055-48-50-6700	\$1.67
Grommet #055-48-60-9140	\$1.80



TRUCK PARTS—ELECTRICAL

Light, LED ID Bar—Red

LED bar lamp improves visibility. Features impact-resistant housing with sonic-sealed shock and vibration-resistant lamp. Manufactured from quality materials to ensure performance and durability.



Part # 055-46-21-9242 \$29.75



Light, LED Marker Light—Red

The world's smallest LED marker lamps for the transportation industry. These little lights are just one inch in diameter and mount in a 3/4 inch hole.

Part # 055-48-20-3305 \$9.98

Light, LED Strip—Red

A compact warning light that provides 14 flash patterns including steady-burn. Surface mounting and small size makes it ideal for areas on your vehicle where effective warning was not possible before.

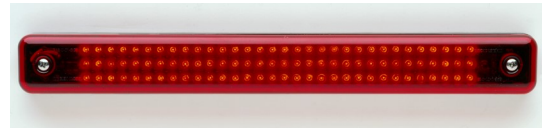

Part #055-57-21-3003 \$76.05



Siren Speaker

Made of black corrosion resistant aluminum, this high-performing 100-watt speaker is designed to withstand the toughest conditions. The slim and lightweight housing mounts easily into the grille, flush between the bumper and hose tray of large apparatus and to most vehicle's bumpers.

Warning: Sirens and Speakers may produce LOUD sounds necessary to request the right-of-way. Sirens and Speakers may cause hearing damage. Wear hearing protection.

Part # 055-79-15-0100 \$180.55

Bulb, JetSolaris LIGHTBAR WORK LIGHT

Replacement bulb for JetSolaris lightbar Work & Alley lights.
(See page 75 for dozer bulbs)

Part # 055-57-10-2002 \$21.55



TRUCK PARTS—ELECTRICAL

Light, LED Clearance/Marker—Red

Low-amp draw of LED with surface-mount design makes these lamps easy to install. Sealed lamps provide better protection from moisture intrusion. Self-grounding eyelet grounds lamp when attached to metal plate. 2-1/2" oval, red.



Part # 055-48-20-4500 \$13.69

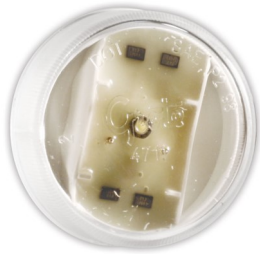

Light, LED Courtesy—Clear

Bright, single LED provides ample light for tool boxes, cabinets, and other hard to light areas. 2" round, clear.

Part # 055-46-30-6056 \$14.95

Replacement Bulbs for John Deere dozers & Heavy Unit worklights

2" diameter bulb. Available in halogen or LED.

Halogen #055-56-20-2653 \$3.29

LED #055-56-20-2005 \$5.50



Replacement Strobe Lights for dozers

Aveo LED—the world's smallest and brightest total coverage LED anti-collision light. Requires no separate power supply. Waterproof, dust proof, and shock proof.

LED #055-57-20-1000 \$495.00



FIRE PLOW & PARTS

PARTS AVAILABLE FOR ORDER LISTED BELOW. ALL OTHER REPAIR PARTS MUST BE REQUESTED THROUGH THE R&D CENTER SHOP MANAGER.

John.Collom@wisconsin.gov

715-619-0262

These items are charged to Fleet. Please provide fleet # in comments section when ordering.

Part #	Description
999-50-10-5500	Assy.; Latch Pin
999-50-30-5002	Pin; Vertical; Depth Adjuster
999-50-40-8152	Plow Hose; 52"
999-50-40-8175	Plow Hose; 75"
999-50-40-8197	Plow Hose; 97"

NOTES:

999-50-40-8152 Plow Hose for Enviro Cab 450J & D4 Cat

999-50-40-8175 Plow Hose for All Dozers

999-50-40-8197 Plow Hose for Open Cab 450



460-46-10-8010	HYDRAULICS; FITTING; PIONEER; MALE	\$8.92
460-46-10-8250	HYDRAULICS; FITTING; PIONEER; FEMALE	\$15.64

DOZER BLADE HOSES

Part #	Description	Price
999-40-50-4100	Dozer; Blade Hose Kit; 450 H/J	\$110.97
999-40-50-4101	Dozer; 450 H/J; Blade Hose; 72"	\$30.96
999-40-50-4103	Dozer; 450 H/J; Blade Hose; 46"	\$24.11
999-40-50-4105	Dozer; 450 H/J; Blade Hose; 23"	\$21.68
999-40-50-8300	Dozer; Blade Hose Kit; CAT D4K	\$87.94
999-40-50-8317	Dozer; CAT D4K; Blade Hose; 17"	\$27.61
999-40-50-8321	Dozer; CAT D4K; Blade Hose; 21"	\$25.11



MISC DOZER PARTS

Light Assembly; 2" Halogen/LED

Worklight used on John Deere dozers and rear of Type 4 engines. Common replacement parts listed below.

Part # 999-30-10-5001 \$36.73

Ref	Part #	Description	Price
10	055-56-20-2653	Halogen Bulb	\$3.29
10	055-56-20-2005	LED Bulb	\$5.50
11	765-83-58-1014	Grommet; Bulb	\$10.00
12	765-83-58-1020	Plate; Bulb Retainer	\$16.75
13	765-83-58-1013	Washer; M6 x 12 x 1.6	\$0.10
14	765-83-58-1013	Cap Screw; M6 x 16MM	\$0.25

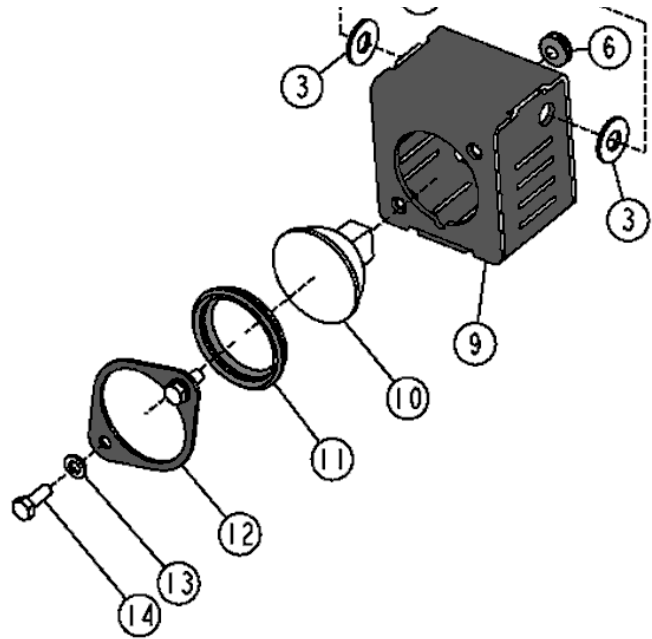

Hose, Dozer Suction/Discharge

Required for Tractor Plow. Hose is 1" diameter x 15 feet long with male and female hose couplings.

Part # 340-56-30-1015 \$53.30



SPECIALTY ASSEMBLIES & PARTS

Hose, Discharge, Cab Protection

Required hose for cab protection of Type 6X and 8X units. The hose is 1" diameter by 25 feet long with couplings. The hose for the Type 4X is 1-1/2" diameter by 25 feet long with couplings.

1"	#340-56-20-1002	\$71.40
1-1/2"	#340-56-20-1502	\$68.25



Dozer Pull-Out Chain

Required for Tractor Plow units. The chain is 1/2" grade 70 chain, 5 feet long with a grab hook on one end.

Part #999-40-40-6100	\$34.34
----------------------	---------



Tow Chain

Required for Type 4X and Tractor Plow units. The chain is 1/2" grade 70 chain, 16 feet long with a grab hook on one end and a slip hook on the other.

Part #999-90-99-9100	\$119.00
----------------------	----------



Custom Length Hose Assemblies

When order custom hose assemblies please be sure to specify the following:

- 1) Hose size—3/4, 1, 1-1/2, etc.
- 2) Hose type—Discharge, Booster, Suction
- 3) Coupling type—Male or Female
- 4) Overall length as measured in picture below (end of couplings)

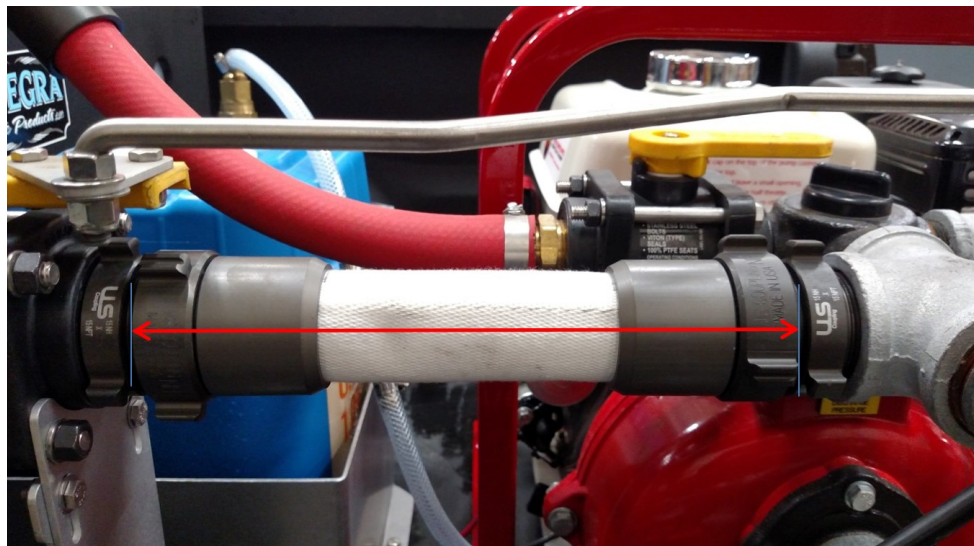

SPECIALTY ASSEMBLIES & PARTS

Assy.; Tank Fill Plug

4" locking plug with pressure relief vents. Includes chain assembly for retention. Used on Type 4x foam tanks and Dozer water tanks.

#999-40-20-7999 \$17.70

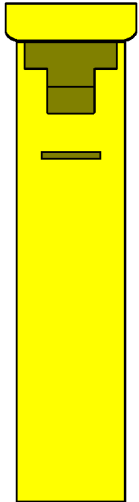
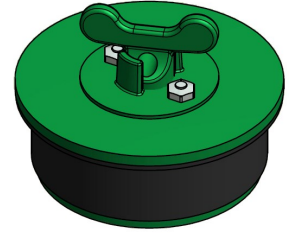

Self-Registration Box

Steel box for collection of registration/payments. Includes internal, removeable cash box with hasp for padlock. Powder coated, 3/16" thick steel construction. 6" W x 8" D x 28" H

999-90-10-5033 \$152.50

Universal Cradle

Cradle for electronic devices – iPad Mount. Compatible tablet sizes: width - 7" (17.8cm) to 9.25" (23.5 cm), depth - 0.79" (2.0 cm) maximum, height - dependent on tablet width. Made of PC-ABS thermoplastic for strength, heat resistance, and finish. Use with Universal Flex Arm Mount sold below.

055-16-24-0301 \$125.56



Universal Flex Base Arm

Flex Arm Package Including Flex Arm And Mounting For Flat Surfaces – Intended for lightweight keyboard or tablet applications up to 5lbs. Total weight.

055-16-24-0101 \$103.87



SPECIALTY ASSEMBLIES & PARTS

Mudflap, Smokey Bear—**FOR DNR PURCHASE ONLY**

Poly-Rubber Mud Flaps are formulated and blended with a unique compound of elastomers designed to handle extreme temperatures. Poly-Rubber's properties allow it to stay clean — for longer — and is resistant to road chemicals, grease, oils, fuels and salts. They feature mounting holes for easy installation. Designed not to crack, peel, fade or tear, even after years of heavy-duty use. They feature anti-spray grooves that direct water, dirt, mud and other debris down and away from the truck's undercarriage.

20" x 20" #065-30-10-2020 \$18.65
 24" x 24" #065-30-10-2424 \$20.95



Nozzle Holder—Bottom Mount

Made of die cast zinc with chrome plate finish. Fits 1-1/2 in. O.D. tools. Furnished with body gasket.

340-06-10-1001 \$24.50

Nozzle Holder—Side Mount

Made of die cast zinc with chrome plate finish. Fits 1-1/2 in. O.D. tools. Furnished with body gasket.

340-06-10-1003 \$24.50



Gauges—Combination or Vacuum

Vibration- and Corrosion-Resistant Gauge with corrosion-resistant 304 stainless steel case with a glycerin-filled dial that reduces needle flutter. Available with Dual Scale or Vacuum only. 2-1/2" Dial, 1/4 NPT Male Center Back Connection.

Gauge, Combination (0-200PSI &	30-0 In Hg)	#025-60-42-0030	\$37.07
Gauge, Vacuum (30-0 In Hg)		#025-60-42-0200	\$37.07



SPECIALTY ASSEMBLIES & PARTS

Antenna; BK P150; 10.5

10.5 inch flexible antenna for Bendix King KNG P150 series radios. This antenna comes with a SMA male connector. High receive antenna is tuned for 150-170 MHz frequencies.

725-82-74-0105 \$45.59



Antenna; BK P150; 18

18 inch flexible antenna for Bendix King KNG P150 series radios. This antenna comes with a SMA male connector. High receive antenna is tuned for 148-174 MHz frequencies and 215db gain.

725-82-74-0180 \$55.89



Clamshell for BK

The KAA0120 is an original equipment manufacturer (OEM) orange AA battery clamshell for powering your Bendix King KNG-P series handheld radios. The clamshells attach to your radio and enables the radio to be powered using 8 alkaline AA batteries.

725-82-74-1001 \$23.34



CHAIN, HOOKS & BINDERS

Part #	Description	Price
450-21-10-7012	CHAIN; 1/2; GR70	\$5.49
450-21-10-8012	CHAIN; 1/2; GR80	\$5.27



Part #	Description	Price
450-19-91-0038	CHAIN BINDER; RATCHET; 3/8; 9,200 WLL	\$34.95
450-19-91-0012	CHAIN BINDER; RATCHET; 1/2; 13,000 WLL	\$65.99

Part #	Description	Price
450-19-10-7006	CHAIN HOOK; CLEVIS GRAB; 3/8; GR70	\$6.79
450-19-10-8008	CHAIN HOOK; CLEVIS GRAB; 1/2; GR70	\$11.35
450-19-11-8008	CHAIN HOOK; CLEVIS GRAB; 1/2; GR80	\$27.99
450-19-15-7006	CHAIN HOOK; CLEVIS SLIP; 3/8; GR70	\$8.79
450-19-15-7008	CHAIN HOOK; CLEVIS SLIP; 1/2; GR70	\$19.99
450-19-15-8008	CHAIN HOOK; CLEVIS SLIP; 1/2; GR80	\$34.85



Part Number	Description	Price
450-19-40-8008	CHAIN COUPLING; MECHANICAL; 1/2; GR80	\$31.19

