

# **BUREAU OF WATERSHED MANAGEMENT**

## **PROGRAM GUIDANCE**

### **Letter of Map Change (LOMC) Process**

#### **March 4, 2015**

*This document is intended solely as guidance, and does not contain any mandatory requirements except where requirements found in statute or administrative rule are referenced. This guidance does not establish or affect legal rights or obligations, and is not finally determinative of any of the issues addressed. This guidance does not create any rights enforceable by any party in litigation with the State of Wisconsin or the Department of Natural Resources. Any regulatory decisions made by the Department of Natural Resources in any matter addressed by this guidance will be made by applying the governing statutes and administrative rules to the relevant facts.*

---

**Purpose:** In the course of carrying out regulatory responsibility for floodplain management, communities must review and permit development in mapped floodplains that in some cases will affect regulatory flood elevations or floodplain boundaries or will result in relocation of a stream channel. In these cases, the community must advise the applicant that it will be necessary to apply for a Letter of Map Change (LOMC) from the Federal Emergency Management Agency (FEMA). This will trigger the federal review and approval process required to revise the map to reflect changes to the effective Flood Insurance Study (FIS) and accompanying Flood Insurance Rate Map (FIRM).

The purpose of this document is to provide guidance to communities, consulting engineers, applicants and department staff to ensure consistent application of the standards contained herein.

#### **Acronyms Used:**

- BFE – Base Flood Elevation (federal term, equivalent to RFE)
- BMP – Best Management Practices
- CFR – Code of Federal Regulations
- CLOMR – Conditional Letter of Map Revision
- FEMA – Federal Emergency Management Agency
- FIRM – Flood Insurance Rate Map
- LOMC – Letter of Map Change
- LOMA – Letter of Map Amendment
- LOMR – Letter of Map Revision
- LOMR-F – Letter of Map Revision – Fill
- NFIP – National Flood Insurance Program
- RFE – Regional Flood Elevation (state term, equivalent to BFE)
- SFHA – Special Flood Hazard Area

#### **Floodplain Development Standards Guidance & LOMC Process**

This guidance provides step-by-step instructions for the permitting and review process for different types of development in the regulatory floodplain, also known as the Special Flood Hazard Area (SFHA). It includes references to applicable standards in the 2012 Model Floodplain Ordinance (Standard Model and Flood Storage Model) and FEMA requirements for Letters of Map Change (LOMC). This guidance provides the minimum standards for new development and substantial improvements to existing development and provides guidance for when communities/applicants must apply for a LOMC as part of the local permit process. The current WDNR Model Ordinance is

fully compliant with the NFIP minimum standards. Even if your community has not yet adopted the 2012 Model, these requirements must still be followed to remain compliant with the NFIP. All floodplain development, except for certain state or federally-managed projects, requires permits from the local community. For further assistance, please contact your regional Water Management Engineer. Contact information for Water Management Engineers by county can be found at: [http://dnr.wi.gov/topic/floodplains/staff\\_flood.html](http://dnr.wi.gov/topic/floodplains/staff_flood.html).

### **Process for Removing Land/Structures from the SFHA**

The FEMA LOMC process provides options to remove land or structures from the SFHA. Because the vertical margin of error for some FIRMs can be as much as ten feet, a LOMA based on better elevation data can remove the property from the SFHA and the flood insurance purchase requirement. An applicant can also submit an updated engineering study as part of a LOMR application or place fill to remove a property from the SFHA. Local/state standards require that the fill be two feet above the BFE and contiguous to lands outside the floodplain. Federal standards require that specific engineering standards be met if a basement will be placed below the BFE in the filled area. More information is available by searching for "FEMA Technical Bulletin 10-01."

### **Purpose of a LOMC**

A LOMC is the only approved method for revising the effective floodplain information on a FIRM. While the state has specific standards for performing engineering studies and for development in the floodplain, the community must also ensure that the appropriate LOMC is approved and issued by FEMA before permits can be granted for projects which will change the effective floodplain information. The following scenarios will illustrate the importance of following the correct process:

- A parcel of land is shown in the SFHA on the effective FIRM. The owner believes the map is in error and hires a Registered Land Surveyor to do an elevation survey of the property. Because the parcel is in an AE zone with an established BFE, if the surveyor can show that the lowest grade of the parcel is above the BFE the parcel is considered to be outside the SFHA. However, the community cannot issue any development permits for the parcel until the owner has submitted the survey information to FEMA and a LOMA has been issued. If the community did issue permits before receipt of the LOMA, FEMA would declare the structure to be in violation of minimum federal standards.
- A parcel is shown in a Zone A (no BFE) on the effective FIRM. The owner would like to build, but the community informs him that a study must be done to determine the BFE and the floodway boundary for the parcel. The completed study is submitted to the DNR regional engineer for review and is approved. If the study shows a BFE increase of one foot or more, the study cannot be used as the basis for issuing development permits until it has been submitted to FEMA and a CLOMR has been approved and received by the community. If the community did issue permits before receipt of the CLOMR, FEMA would declare the structure to be in violation of minimum federal standards.

## Development Standards

The first step in the permit process is to locate the parcel on the correct FIRM and determine which flood zone it is in. After determining the development requirements for that zone, the community official should consult Section 7.0 of the 2012 WDNR Model Ordinance to determine the correct steps to follow for issuing the appropriate permit(s).

### **New or substantially improved principal building: residential or commercial** Zone A (Flow Chart 1)

Applicable sections of 2012 Model Ordinance:

- *Determining Floodway and Floodfringe Limits* Sec. 5.4 [Standard]
- *Determining Floodway and Floodfringe Limits* Sec. 5.1(4) [Flood Storage]
- *Hydraulic and Hydrologic Studies to Analyze Development* Sec. 7.1(2)(c) [Standard/Flood Storage]
- *Floodfringe District* Sec. 4.0 [Standard/Flood Storage]

Standards

- Study must be approved by DNR regional engineer
- No buildings in floodway
- If located in the floodfringe, fill, elevation and dryland access standards apply

### Zone AE (Flow Chart 2)

Applicable sections of 2012 Model Ordinance:

- *Floodway District* Sec. 3.0 [Standard/Flood Storage]
- *Floodfringe District* Sec. 4.0 [Standard/Flood Storage]

Standards

- No buildings in floodway
- Fill, elevation and dryland access standards apply
- Section 5.4 applies in Zone AE floodplains with no floodway depicted

### **New or substantially improved accessory structure**

#### Zone A (Flow Chart 1)

Model Sections

- *Determining Floodway and Floodfringe Limits* Sec. 5.4 [Standard]
- *Determining Floodway and Floodfringe Limits* Sec. 5.1(4) [Flood Storage]
- *Hydraulic and Hydrologic Studies to Analyze Development* Sec. 7.1(2)(c) [Standard/Flood Storage]
- *Floodfringe District* Sec. 4.0 [Standard/Flood Storage]

Standards

- Study must be approved by DNR regional engineer
- Elevation standards apply
- No buildings in floodway

## Zone AE (Flow Chart 2)

### Model Sections

- *Floodway District* Sec. 3.0 [Standard/Flood Storage]
- *Floodfringe District* Sec. 4.0 [Standard/Flood Storage]

### Standards

- No buildings in floodway
- Elevation standards apply
- Section 5.4 applies in Zone AE floodplains with no floodway depicted

## **Non-building development**

### Zone A (Flow Chart 1)

#### Model Sections

- *Determining Floodway and Floodfringe Limits* Sec. 5.4 [Standard]
- *Determining Floodway and Floodfringe Limits* Sec. 5.1(4) [Flood Storage]
- *Hydraulic and Hydrologic Studies to Analyze Development* Sec. 7.1(2)(c) [Standard/Flood Storage]
- *Floodfringe District* Sec. 4.0 [Standard/Flood Storage]

#### Standards

- Minor projects may be exempted (see Appendix A); community must consult with DNR regional engineer to determine study requirements
- If study is required and the project increases the BFE; either
  - Increase must be contained on applicant's property; or
  - Flooding easements must be obtained and submitted to the Water Management Engineer prior to approval
- Projected BFE increases of one foot or more require a CLOMR submittal (44CFR 60.3 (c)(10))
- Lesser increases must be tracked by the community and submitted for CLOMR when cumulative increase exceeds one foot
- Review of CLOMR applications by the Water Management Engineer is recommended
- New subdivisions and developments of over 5 acres or 50 lots require engineering study using standards in Model Section 7.1(2)(c) *Hydraulic and Hydrologic Studies to Analyze Development*

## Zone AE – Floodway (Flow Chart 2)

### Model Sections

- *Floodway District* Sec. 3.0 [Standard/Flood Storage]
- *Floodfringe District* Sec. 4.0 [Standard/Flood Storage]

Standards

- Any development requires encroachment analysis
- If the project causes any increase in BFE or floodway change; either
  - Applicant must apply for and receive a CLOMR before local permits can be issued and apply for a LOMR to reflect changes within six months after completion; or
  - Project must be redesigned to avoid any changes to BFE or floodway
- If the project causes any decrease in BFE, applicant must apply for a LOMR to reflect changes within six months after completion
- Review of CLOMR applications by the Water Management Engineer is recommended
- Section 5.4 applies in Zone AE floodplains with no floodway depicted

Zone AE –Floodfringe (Flow Chart 2)

Model Sections

- *Floodfringe District* Sec. 4.0 [Standard/Flood Storage]

Standards

- encroachment analysis not required

**Approved:**

  
Waterway PMT

3.5.2015  
Date

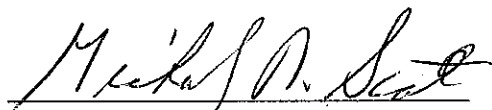
  
Michael Scott, Staff Attorney

3/4/15  
Date

  
Pamela Biersach, Watershed Bureau Director

3-5-2015  
Date

## Appendix A: Flow Charts

### Zone A permit process flow chart (Flow Chart 1)

Applicants must submit the study to the community using standards in Model Section 7.1(2)(c) *Hydraulic and Hydrologic Studies to Analyze Development*. If structure/site is above BFE, issue permit conditioned on applicant applying to FEMA for a LOMA. The DNR WME must review and approve the study prior to the issuance of any permits. If below BFE, submit analysis delineating the floodway on the effective FIRM.

If site is in floodfringe, issue local permits in compliance with Model Section 4.0 *Floodfringe District*. If site is in floodway, no buildings allowed; other development limited to <1.0 foot increase in BFE, increase contained on applicant's property or obtain easements from all affected property owners

If development causes more than a 1.0 foot rise, applicant must apply for a CLOMR from FEMA [44CFR 60.3(b)4, (d)2, (d)3].

### Zone AE permit process flow chart (Flow Chart 2)

If no floodway is shown on the FIRM, the applicant must submit a study using standards in Model Section 7.1(2)(c) *Hydraulic and Hydrologic Studies to Analyze Development*. If not in mapped floodway on the FIRM, no CLOMR is required; issue local permits. If the development is in a mapped floodway as shown on the FIRM, does the development cause any BFE or floodway change? If no, prepare no-rise certificate; no CLOMR required. If yes, submit CLOMR application to FEMA (44CFR 65.12 criteria). If CLOMR approved, community issues local permits. If denied, local permits denied.

**ZONE A DEVELOPMENT FLOW CHART (1)**

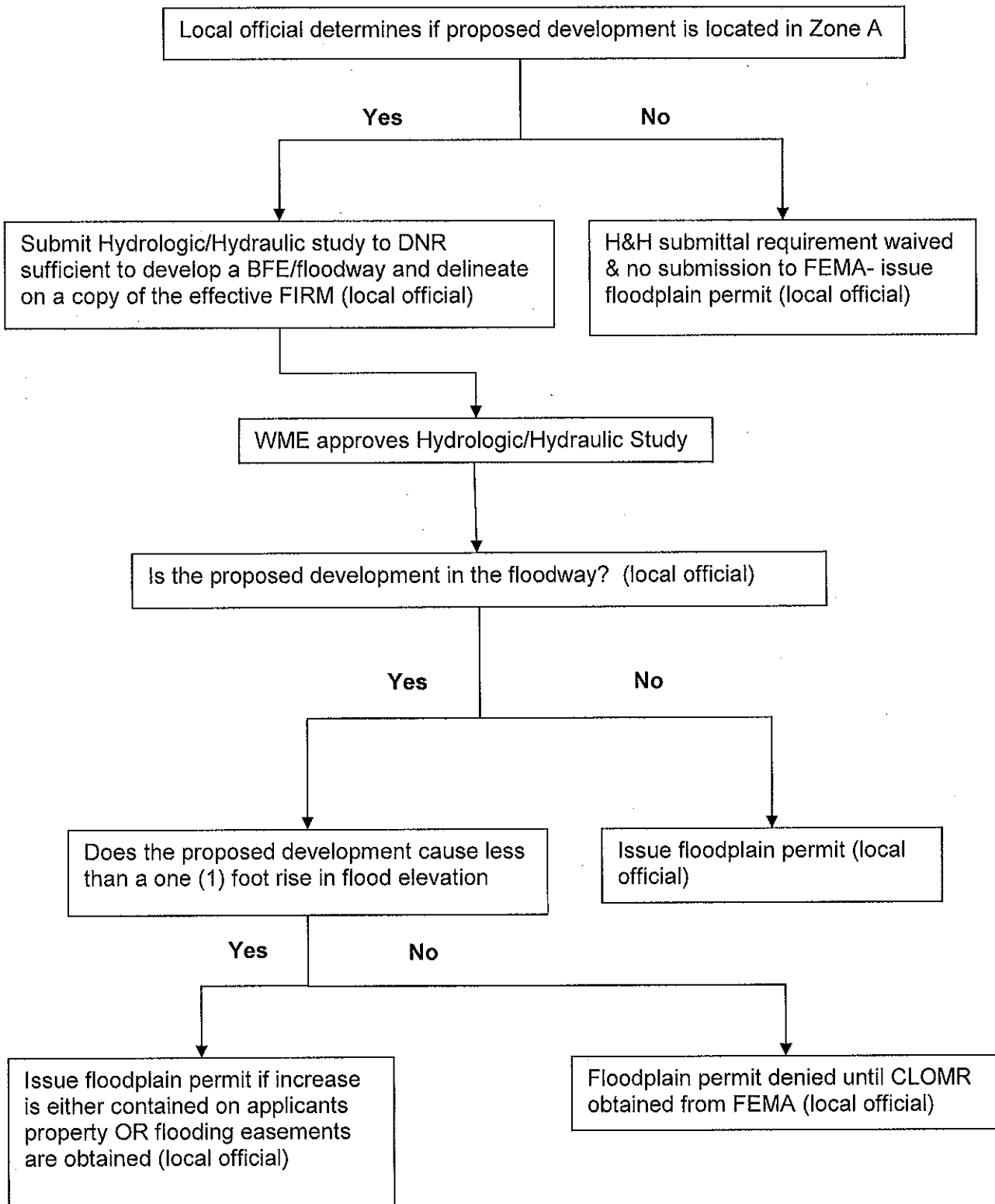

### Explanation of flow chart for Zone A

- Step 1. Local official determines if the proposed development is in a Zone A floodplain.
- Step 2. Local official submits applicant-provided analysis and map that displays a floodway on a copy of the effective FIRM panel and requests DNR review.
- Step 3. Local official determines if the proposed development is in the mapped floodway based on department-approved flood study.
- Step 4. A floodway encroachment study is required for development in the floodway. If the WME determines that the proposed development causes less than a one (1) foot increase, the approved study is then used by ZA to apply ordinance requirements.
- Step 5. Local official determines if the increase is contained on the applicant's property or the applicant can obtain easements from affected property owners.
- Step 6. If the increase is one (1) foot or greater, local official notifies applicant that they must apply for a CLOMR from FEMA before a building permit can be issued.

**Note:** Provided that the project meets all other applicable provisions in the ordinance. Hydraulic analysis to 2 decimal places only. (Step 4)

**Note:** If the DNR calculated an approximate BFE for the stream, the community can obtain that data from the department for use in issuing permits. If the building site is above the calculated BFE, floodplain development standards do not apply. (Step 1)

**Note:** Although a LOMC is not always required after the DNR has approved an analysis, it is recommended and will be helpful when the property is sold. (Step 6)

**Note:** If project is located in a mapped flood storage area, flood storage standards apply.



**ZONE AE DEVELOPMENT FLOW CHART (2)**

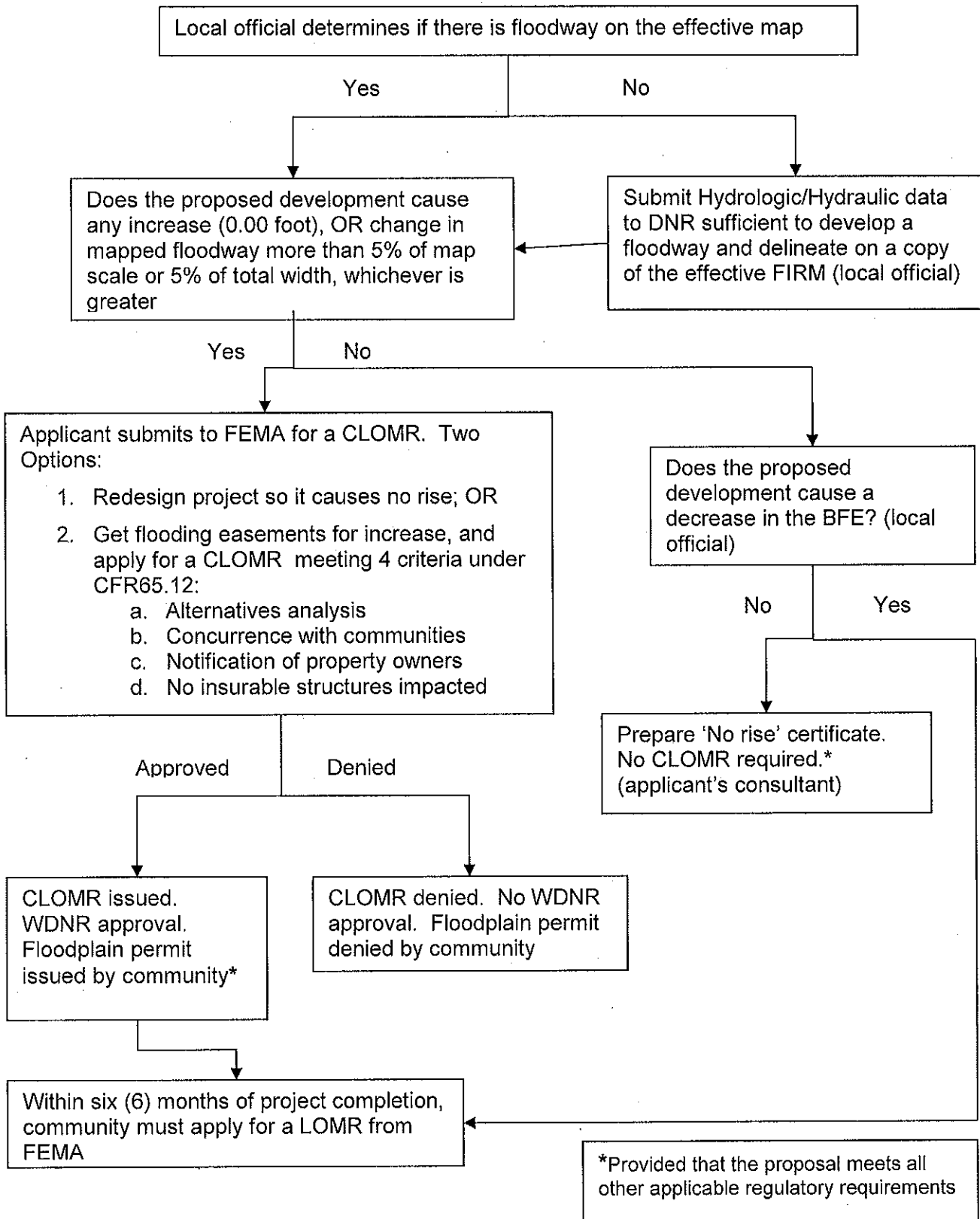

### Explanation of flow chart for Zone AE

- Step 1. Local official determines if the proposed development is in the mapped floodway on the effective FIRM panel.
- Step 2. Local official submits applicant's analysis and copy of the effective FIRM panel that displays the location of the proposed development and requests DNR review.
- Step 3. WME determines if the proposed development increases or decreases the BFE or increases or decreases the mapped floodway more than 5% of map scale or 5% of total width, whichever is greater. \*
- Step 4. If no increase or decrease in BFE is shown, applicant's consultant prepares a No rise certificate, submits to local official.
- Step 5. If decrease in BFE shown; applicant submits to FEMA for a LOMR to revise the floodplain within six (6) months of project completion.
- Step 6. If increase shown, applicant submits to FEMA for a CLOMR.
- Step 7. After CLOMR issuance and DNR approval, applicant submits to FEMA for a LOMR to revise the floodway within six (6) months of project completion.

\* Note: Provided that the project meets all other applicable provisions in the ordinance. Hydraulic analysis to 2 decimal places only.

**Note:** If project is located in a mapped flood storage area, flood storage standards apply.

## Appendix B: Minor Projects in Zone A Floodplains

Non-structural activities whose primary purpose is the maintenance or restoration of existing habitat protection or infrastructure projects which are deemed to have minimal impacts on floodplain characteristics and do not require code-compliant engineering studies if the following criteria are met:

- Insurable structures will not be affected
- Project is located in an undeveloped area (per NR 116 definition) and department review concludes that only the applicant's property would be affected by the proposal

This exception only applies to minor projects in undeveloped areas and cannot be approved in conjunction with any other development. Examples of exceptions include:

- Dredging (not below the natural stream grade or historic profile) with placement of spoils outside of effective flow areas
- Minor filling below the natural surrounding grade if not in mapped flood storage area
- Wetland restoration projects with minimal profile change to the topography
- Road/shoulder maintenance and repair
- Dam/embankment repairs or minor modifications
- Grading/excavating which results in no net loss in flood storage volume
- Habitat improvements with BMPs
- Streambank restorations with BMPs

Waterway crossings in approximate A zones may be permitted if the following simplified method is used by the applicant to determine the effects of the proposed crossing (Figure 1). The applicant must submit the information to the local official for review in consultation with the regional engineer:

- Using contour lines upstream and downstream of the crossing site, divide elevation difference by distance between contours to determine stream slope (**s**)
- Determine the height of project fill (bottom of stream bed to top of fill) (**y**)
- Determine the upstream limit of potential BFE increase (**d**) by dividing the total fill elevation by stream slope, then measure the result on quad map along the stream centerline
- Ensure that the resulting rise is contained on the applicant's property

Pivot bridges, clear span bridges (figure 2) and simple culvert crossings (figure 1) with minimal approach fill may be considered minor projects.

**Note:** If project is located in a mapped flood storage area, flood storage standards apply.

## Figure 1 - Simple Culvert Crossing Calculations

Calculate slope (s) of the stream at the project site in ft/ft  
 $s = (\text{upstream contour elevation} - \text{downstream contour elevation}) / L$

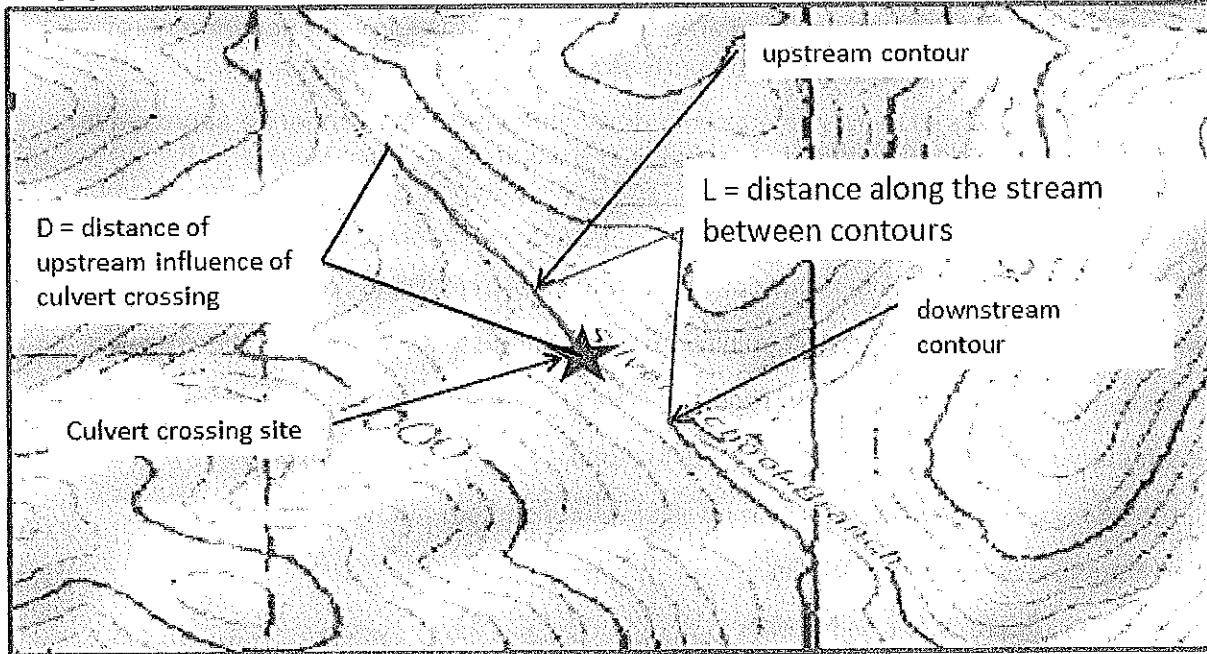

Calculate height of fill (y) in feet

$$y = \text{top of fill} - \text{stream bottom}$$

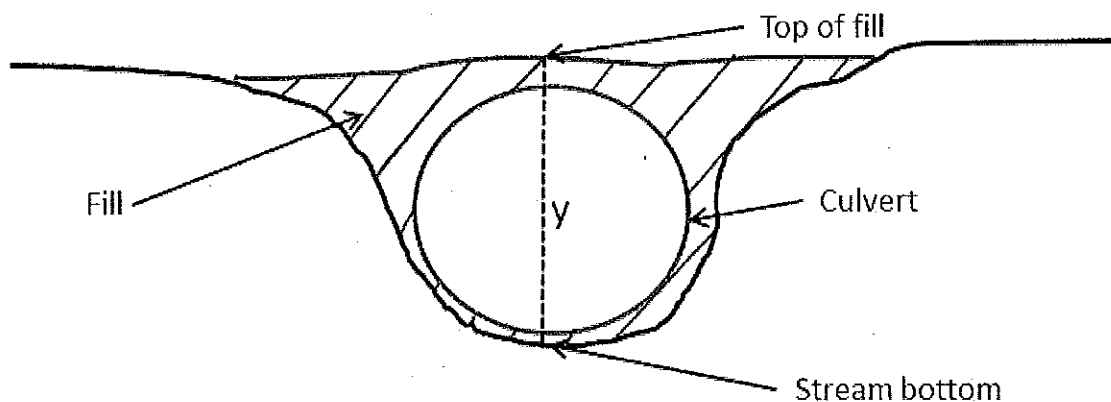

Calculate distance (d) of upstream influence

$$d = y/s$$

# Figure 2 - Clear Span Bridge

